

Ultrasonic flow meter

For custody transfer of gases

Model FLC-UFL

WIKA data sheet FL 40.01

Applications

- Industrial gases
- Oil and gas
- Petrochemical industry
- Power supply
- Process industry

Special features

- Patented broadband continuous-wave technology
- Simultaneous transmission on two or more paths
- No pressure drop and no wear parts
- Intrinsically safe design
- Approved for custody transfer (MID MI-001, OIML R49)

Description

By calculating velocity ratios between two or more ultrasonic paths, the simply constructed model FLC-UFL ultrasonic flow meter provides reliable gas flow measurement. Additional measured variables, such as sound velocity, signal-to-noise ratio or signal strength, are available for condition monitoring. For applications requiring integrated volume conversion, pressure and temperature sensors can be connected.

The flow meters are certified intrinsically safe for zone 0 in accordance with ATEX/IECEX and allow for easy and quick installation and commissioning since no special provisions for wiring and case are required.

The patented broadband continuous-wave technology ensures low-noise and reliable measurements, even in the most demanding applications. The epoxy-coated aluminium-alloy electronics case has an ingress protection of IP66 and NEMA 4X for outdoor use.

For offshore applications, a version in stainless steel is available. The wetted parts are made from titanium and designed for process gas temperatures of -30 °C [22 °F] up to +80 °C [+176 °F].



Ultrasonic flow meter, model FLC-UFL

The model FLC-UFL provides comprehensive flow and diagnostic information on the local display and remotely via a PC software interface, enabling real-time data logging and condition monitoring.

The display shows an overview of the instrument's set parameters, such as units, pipe size and ultrasonic path configuration. Traceability information such as firmware version, checksums and serial numbers are also displayed.

The model FLC-UFL is supplied, as standard, with a pulse/frequency output and a USB port for commissioning and service. Via option boards, an isolated RS485 and two additional isolated pulse/frequency outputs as well as a 4 ... 20 mA/HART® output can be provided.

Specifications

Model FLC-UFL				
	Model FLC-UFL 1/2	Model FLC-UFL 3/3F	Model FLC-UFL 4F	Model FLC-UFL 4F Duo
Measurement principle	Transit time, broadband continuous-wave			
Available pipe diameters	<ul style="list-style-type: none"> ■ 2 ... 96"; (150, 300 lb) ■ 2 ... 30"; (600, 900 lb) 	2 ... 16"; (150, 300, 600 lb)	3 ... 30"; (150, 300, 600, 900 lb)	8 ... 30"; (300, 600, 900 lb)
Available flange standards	<ul style="list-style-type: none"> ■ ANSI ■ DIN 			
Pressure ranges	To 153 bar [2,250 psi]	To 102 bar [1,480 psi]	To 153 bar [2,250 psi]	To 153 bar [2,250 psi]
Accuracy	Model FLC-UFL 1 ¹⁾ : <ul style="list-style-type: none"> ■ 2 % (> 3 m/s) ■ 3 % (0.1 ... 3 m/s) 	Factory calibration: <ul style="list-style-type: none"> ■ 1 % ($Q_t - Q_{max}$) ■ 2 % ($Q_{min} - Q_t$) 	Factory calibration: <ul style="list-style-type: none"> ■ 0.5 % ($Q_t - Q_{max}$) ■ 1 % ($Q_{min} - Q_t$) 	On request
	Model FLC-UFL 2 ¹⁾ : <ul style="list-style-type: none"> ■ 1.5 % (> 3 m/s) ■ 2 % (0.1 ... 3 m/s) 	Flow calibration: <ul style="list-style-type: none"> ■ 0.5 % ($Q_t - Q_{max}$) ■ 1 % ($Q_{min} - Q_t$) 	Flow calibration: <ul style="list-style-type: none"> ■ 0.2 % ($Q_t - Q_{max}$) ■ 0.5 % ($Q_{min} - Q_t$) 	
Medium temperature	<ul style="list-style-type: none"> ■ -30 ... +80 °C [-22 ... +176 °F] (standard) ■ -40 ... +120 °C [-40 ... +248 °F] (option) 	-30 ... +80 °C [-22 ... +176 °F]		
Ambient temperature	-40 ... +60 °C [-40 ... +140 °F]			
Flow range	0.1 ... 65 m/s			
Repeatability	0.2 %	0.1 %		
Turndown ratio	650:1 (depending on pipe diameter and application)	100:1 (depending on pipe diameter)		
Standards	-	AGA-9-compliant	<ul style="list-style-type: none"> ■ AGA-9-compliant ■ OIML R137-1 and -2 ■ MID 2014/32/EU 	<ul style="list-style-type: none"> ■ AGA-9-compliant ■ OIML R137-1 and -2 ■ MID 2014/32/EU
Case material	<ul style="list-style-type: none"> ■ Carbon steel, ASTM A350-LF2 Cl.1 ■ Stainless steel, ASTM A182-F316 			
Material of the electronic case	Low-copper aluminium alloy, epoxy-painted			
Transducer	On request	<ul style="list-style-type: none"> ■ All-metal, Ti grade 2 ■ Retractable version optional 	<ul style="list-style-type: none"> ■ All-metal, titanium ■ Retractable version optional 	
Connection for pressure measuring instrument	<ul style="list-style-type: none"> ■ ¼ or ½ NPT, female thread ■ Optionally with absolute pressure sensor ■ Valve manifolds on request 	<ul style="list-style-type: none"> ■ ¼ NPT, female thread ■ Others on request 		<ul style="list-style-type: none"> ■ ¼ NPT, female thread ■ Others on request
Connection for temperature measuring instrument	<ul style="list-style-type: none"> ■ ½ or ¾ NPT, female thread ■ Optionally with PT100 4-wire temperature sensor ■ Thermowells on request 	-	-	-
IP ingress protection	IP66, NEMA 4X			
Cable entry	<ul style="list-style-type: none"> ■ M20 x 1.5, female thread ■ ½ NPT, female thread 			
Supply voltage	<ul style="list-style-type: none"> ■ Mains power: DC 12 ... 28 V, max. 670 mW ■ Option board: DC 12 ... 28 V, max. 225 mW 	<ul style="list-style-type: none"> ■ Mains power: DC 14 ... 28.8 V, max. 670 mW ■ Option board: DC 10.8 ... 28.8 V, max. 225 mW 		<ul style="list-style-type: none"> ■ Mains power: DC 14 ... 29 V, max. 670 mW ■ Option board: DC 14 ... 29 V, max. 225 mW
User interface	128 x 128 dot matrix LC display, 4 buttons			

Model FLC-UFL				
	Model FLC-UFL 1/2	Model FLC-UFL 3/3F	Model FLC-UFL 4F	Model FLC-UFL 4F Duo
Interface connections	<ul style="list-style-type: none"> ■ 1 USB output (not intrinsically safe) ■ 1 HF frequency output 	<ul style="list-style-type: none"> ■ 1 USB output (not intrinsically safe) ■ 1 frequency output 	<ul style="list-style-type: none"> ■ 1 USB output (not intrinsically safe) ■ 1 HF frequency output/LF pulse output 	
Communication protocols	Modbus® (RS485 and USB)			
Ex approvals	<ul style="list-style-type: none"> ■ ATEX EX II 1 G Ex ia IIC T4 Ga, zone 0 ■ IECEx Ex ia IIC T4 Ga 	<ul style="list-style-type: none"> ■ ATEX EX II 1 G Ex ia IIC T4 Ga, zone 0 ■ IECEx Ex ia IIC T4 Ga ■ FM class I, division 1, group A, B, C, D T4 (in application) 	<ul style="list-style-type: none"> ■ ATEX EX II 1 G Ex ia IIC T4 Ga, zone 0 ■ IECEx Ex ia IIC T4 Ga ■ CSA/FM class I, division 1, group A, B, C, D T4 	

1) Typical accuracy of the flow calibration on request

Other pipe diameters, flange standards, pressure ranges and case materials on request.

Optional interface connections	
Model FLC-UFL 1/2	E/A option board <ul style="list-style-type: none"> ■ 1 x RS485, 2-wire, externally powered ■ 2 x digital, configurable via software (HF, LF, status)
	PT option board <ul style="list-style-type: none"> ■ Pressure and temperature sensors
	4 ... 20 mA option board <ul style="list-style-type: none"> ■ 1 x 4 ... 20 mA loop-powered output
Model FLC-UFL 3/3F	E/A option board <ul style="list-style-type: none"> ■ 1 x RS485, 2-wire, externally powered ■ 2 x digital, configurable via software
	PT option board <ul style="list-style-type: none"> ■ Pressure and temperature sensors
	4 ... 20 mA option board <ul style="list-style-type: none"> ■ 1 x 4 ... 20 mA loop-powered output
Model FLC-UFL 4F	E/A option board <ul style="list-style-type: none"> ■ 1 x RS485, 2-wire, externally powered ■ 2 x digital, configurable via software (HF, LF, status)
	PT option board <ul style="list-style-type: none"> ■ Pressure and temperature sensors
	4 ... 20 mA option board <ul style="list-style-type: none"> ■ 1 x 4 ... 20 mA loop-powered output
Model FLC-UFL 4F Duo	Option board slot 1 <ul style="list-style-type: none"> ■ 1 x RS485, 2-wire, externally powered ■ 2 x digital, configurable via software (HF, LF, status)
	Option board slot 2 <ul style="list-style-type: none"> ■ Pressure and temperature sensors
	4 ... 20 mA option board <ul style="list-style-type: none"> ■ 1 x 4 ... 20 mA loop-powered output

Model FLC-UFL 1/2

Gas flow measurement

The models FLC-UFL 1 and 2 are suitable for various and also changing gas compositions, such as in flare gas and venting applications or biogas measurements. With high turndown ratios and customer-specific designs, the model can be supplied in single or dual configuration with direct path alignment, horizontal or vertical alignment and diameter or top mounting (90°) for large pipes.

Simplified design

With only one printed circuit board containing all the circuits, the models FLC-UFL 1 and 2 are very simple in construction. Both optional expansion boards are fitted directly onto the main board.

Measurands

- Velocity
- Actual volumetric flow
- Standard or normal volumetric flow
- Mass flow calculation
- Molecular weight calculation

The model FLC-UFL 1 and 2 features versatile input and output options, including optional pressure and temperature sensors:

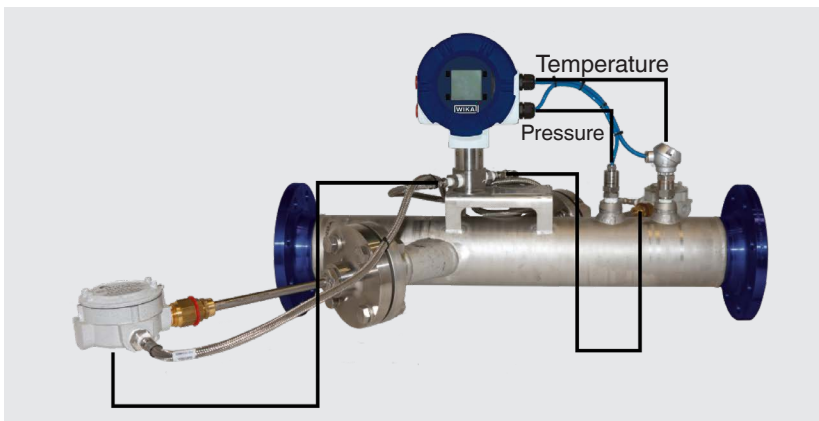

Model FLC-UFL 3/3F

The models FLC-UFL 3 and 3F offer a reliable and precise measurement of gas flow, even in extreme applications. Versions for non-fiscal measurements (model FLC-UFL 3) and for fiscal measurements (model FLC-UFL 3F) are available.

Features

- Patented broadband continuous-wave technology
- Available in sizes 2 ... 16" and in pressure ratings 150, 300 and 600
- AGA-9-compliant (model FLC-UFL 3F)
- Tools for the removal and replacement of sensors under pressure are available
- Integrated pressure and temperature sensors as a solution for PTZ calculation, volume conversion, molecular weight calculations for flare gas or biogas with methane concentration
- Extensive inputs and outputs, including optional pressure and temperature sensors, digital and analogue 4 ... 20 mA outputs and RS485 Modbus® communication

Model FLC-UFL 3/3F with three ultrasonic paths:

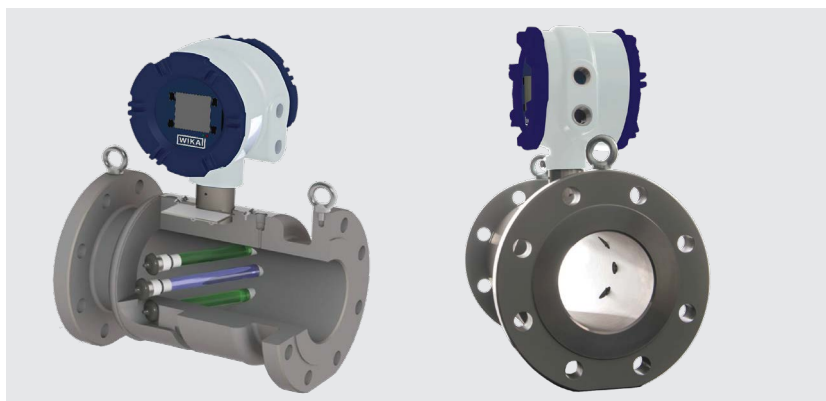

Model FLC-UFL 3/3F - flow ranges ¹⁾						
Nominal size ANSI [“] / DIN [DN]	Schedule	Inner diameter in mm [inch]	Flow in m ³ /h [cf/h]			Turndown ratio
			Q _{max}	Q _t	Q _{min}	
2" / DN 50	40	52.5 [2.067]	320 [11,010]	32 [1,101]	4 [130]	80 [85]
	80	49.3 [1.939]	280 [9,690]	28 [969]	4 [110]	70 [89]
3" / DN 80	40	77.9 [3.068]	610 [21,230]	61 [2,123]	7 [250]	88 [85]
	80	73.7 [2.9]	540 [18,970]	54 [1,897]	7 [220]	78 [87]
4" / DN 100	40	102.3 [4.026]	1,000 [34,980]	100 [3,498]	12 [420]	84
	80	97.2 [3.826]	900 [31,600]	90 [3,160]	11 [380]	82 [84]
6" / DN 150	40	154.1 [6.065]	2,020 [71,090]	202 [7,109]	21 [720]	97 [99]
	80	146.3 [5.761]	1,820 [64,150]	182 [6,415]	19 [650]	96 [99]
8" / DN 200	40	202.7 [7.981]	3,490 [123,100]	349 [12,310]	35 [1,240]	100
	80	193.7 [7.625]	3,190 [112,370]	319 [11,237]	32 [1,130]	100
10" / DN 250	40	254.5 [10.02]	5,500 [194,100]	550 [19,410]	55 [1,950]	100
	80	242.9 [9.562]	5,100 [176,700]	510 [17,670]	51 [1,770]	100
12" / DN 300	STD	304.7 [11.938]	7,900 [278,200]	790 [27,820]	79 [2,790]	100
	80	289 [11.376]	7,100 [250,200]	710 [25,020]	71 [2,510]	100
14" / DN 350	STD	336.5 [13.126]	9,700 [339,200]	970 [33,920]	97 [3,400]	100
	80	317.5 [12.5]	8,600 [302,000]	860 [30,200]	86 [3,020]	100
16" / DN 400	STD	378.3 [15]	12,800 [449,500]	1,280 [44,950]	128 [4,500]	100
	80	363.5 [14.314]	11,300 [395,900]	1,130 [39,599]	113 [3,960]	100
18" / DN 450	STD	437.9 [17.24]	16,300	1,630	163	100
	80	409.3 [16.114]	14,300	1,430	143	100
20" / DN 500	XS	482.6 [19]	19,800	1,980	198	100
	80	455.6 [17.937]	17,700	1,770	177	100
24" / DN 500	XS	584.6 [23.016]	28,100	2,810	290	97
	80	547.7 [21.563]	24,600	2,460	255	97
30" / DN 750	30	730.2 [28.748]	42,300	4,230	453	94
	wt = 35	692 [27.244]	38,000	3,800	407	94

1) The actual weight and dimensions can be changed for special designs.

Dimensions, model FLC-UFL 3/3F

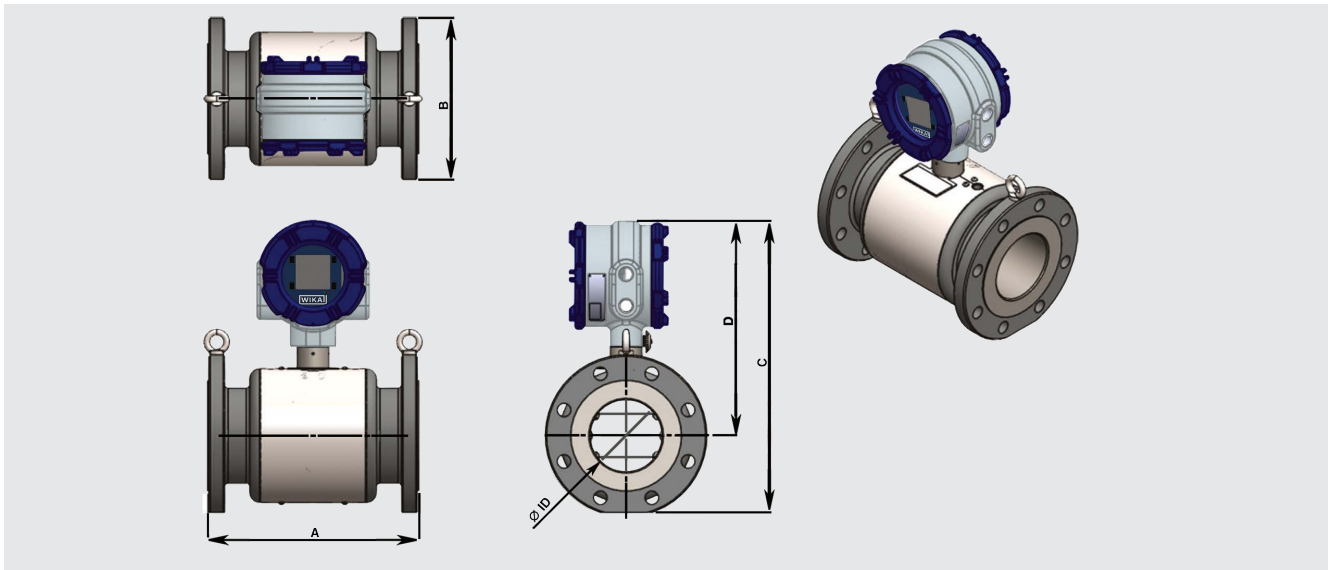

Model FLC-UFL 3/3F - dimensions and weight ¹⁾					
Nominal size (ID)	Pressure rating	Length A in mm [inch]	Width B in mm [inch]	Height C in mm [inch]	Weight in kg [lb]
2" / DN 50	150	260 [10.2]	155 [6.1]	340 [13.4]	25 [55]
	300	260 [10.2]	165 [6.5]	346 [13.6]	27 [60]
	600	280 [11]	165 [6.5]	360 [14.2]	30 [66]
3" / DN 80	150	300 [11.8]	190 [7.5]	372 [14.6]	35 [77]
	300	300 [11.8]	210 [8.3]	382 [15]	36 [79]
	600	320 [12.6]	210 [8.3]	400 [15.7]	44 [97]
4" / DN 100	150	300 [11.8]	230 [9.1]	410 [16.1]	43 [95]
	300	300 [11.8]	255 [10]	422 [16.6]	50 [110]
	600	350 [13.8]	275 [10.8]	447 [17.6]	78 [172]
6" / DN 150	150	350 [13.8]	280 [11]	457 [18]	57 [126]
	300	400 [15.7]	320 [12.6]	477 [18.8]	96 [212]
	600	400 [15.7]	355 [14]	510 [20.1]	123 [271]
8" / DN 200	150	450 [17.7]	345 [13.6]	515 [20.3]	145 [320]
	300	500 [19.7]	380 [15]	532 [20.9]	175 [386]
	600	500 [19.7]	420 [16.5]	570 [22.4]	197 [434]
10" / DN 250	300	550 [21.7]	445 [17.5]	610 [24]	245 [540]
	600	550 [21.7]	510 [20.1]	640 [25.2]	303 [668]
12" / DN 300	300	600 [23.6]	520 [20.5]	675 [26.6]	285 [628]
	600	600 [23.6]	560 [22]	695 [27.4]	376 [829]
14" / DN 350	300	600 [23.6]	585 [23]	705 [27.8]	405 [893]
	600	600 [23.6]	605 [23.8]	730 [28.7]	435 [959]
16" / DN 400	300	700 [27.6]	650 [25.6]	755 [29.7]	620 [1,367]
	600	700 [27.6]	690 [27.2]	775 [30.5]	660 [1,455]
18" / DN 450	600	900 [35.4]	745 [29.3]	905 [35.6]	950 [37.5]
20" / DN 500	600	1,000 [39.4]	815 [32.1]	940 [37]	1,150 [45.3]
24" / DN 600	600	1,100 [43.3]	940 [37]	1,010 [39.8]	1,500 [59.1]
30" / DN 750	600	1,300 [51.2]	1,130 [44.5]	1,220 [48]	2,450 [96.5]

1) The actual flow range can vary depending on the application

Model FLC-UFL 4F

Description

With the model FLC-UFL 4F, the measurement of flow through the four ultrasonic paths ensures high accuracy, even with varying flow profiles caused by changes in flow velocity, gas composition, gas pressure or upstream pipe configuration. The fast response time is ensured through the simultaneous transmission on more than one path.

The measured flow profile contains a diagnostics tool. Should one path fail, the path substitution algorithm uses past flow data to reliably continue flow measurements until the path stabilises or corrective action is taken.

Features

- Approved for high-accuracy custody transfer with four ultrasonic paths
- Tested to fulfil the international standards for custody transfer measurements, e.g. AGA-9 and OIML R137 (class 0.5)
- Patented broadband continuous-wave technology
- Very low power consumption in operation
- Extensive diagnostics information, delivered from specialised software
- Robust, high-efficiency, all-metal sensors
- Extensive inputs and outputs, including optional pressure and temperature measurements, for PTZ calculation
- Tools for the removal and replacement of transducers under pressure are available, suitable for pressures up to 153 bar [2,250 psi]

International approvals

- OIML R137-1 and -2-certified (class 0.5)
- AGA-9-compliant
- Measuring instrument directive (MID)

Model FLC-UFL 4F with four ultrasonic paths:

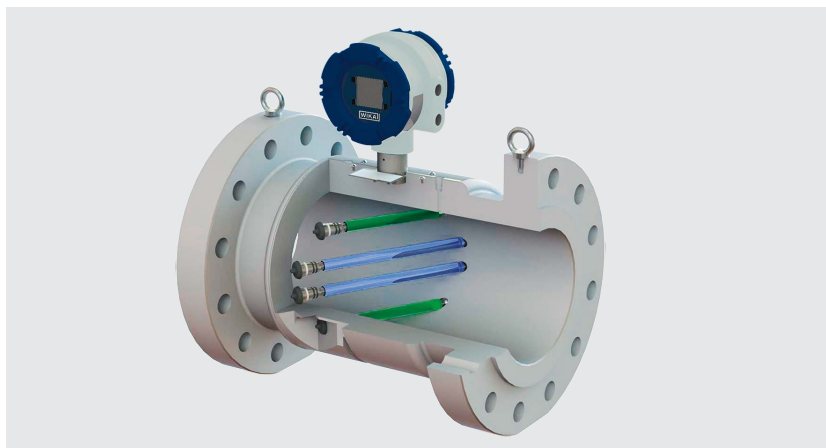

Model FLC-UFL 4F - flow ranges ¹⁾						
Nominal size ANSI [“] / DIN [DN]	Schedule	Inner diameter in mm [inch]	Flow in m ³ /h [cf/h]			Turndown ratio
			Q _{max}	Q _t	Q _{min}	
3" / DN 80	40	77.9 [3.068]	610 [21,230]	61 [2,123]	7 [250]	88 [85]
	80	73.7 [2.9]	540 [18,970]	54 [1,897]	7 [220]	78 [87]
4" / DN 100	40	102.3 [4.026]	1,000 [34,980]	100 [3,498]	12 [420]	84
	80	97.2 [3.826]	900 [31,600]	90 [3,160]	11 [380]	82 [84]
6" / DN 150	40	154.1 [6.065]	2,020 [71,090]	202 [7,109]	21 [720]	97 [99]
	80	146.3 [5.761]	1,820 [64,150]	182 [6,415]	19 [650]	96 [99]
8" / DN 200	40	202.7 [7.981]	3,490 [123,100]	349 [12,310]	35 [1,240]	100
	80	193.7 [7.625]	3,190 [112,370]	319 [11,237]	32 [1,130]	100
10" / DN 250	40	254.5 [10.02]	5,500 [194,100]	550 [19,410]	55 [1,950]	100
	80	242.9 [9.562]	5,100 [176,700]	510 [17,670]	51 [1,770]	100

Model FLC-UFL 4F - flow ranges ¹⁾						
Nominal size ANSI [“] / DIN [DN]	Schedule	Inner diameter in mm [inch]	Flow in m ³ /h [cf/h]			Turndown ratio
			Q _{max}	Q _t	Q _{min}	
12" / DN 300	STD	304.7 [11.938]	7,900 [278,200]	790 [27,820]	79 [2,790]	100
	80	289 [11.376]	7,100 [250,200]	710 [25,020]	71 [2,510]	100
14" / DN 350	STD	336.5 [13.126]	9,700 [339,200]	970 [33,920]	97 [3,400]	100
	80	317.5 [12.5]	8,600 [302,000]	860 [30,200]	86 [3,020]	100
16" / DN 400	STD	387.3 [15]	12,800 [449,500]	1,280 [44,950]	128 [4,500]	100
	80	363.5 [14.314]	11,300 [395,900]	1,130 [39,590]	113 [3,960]	100
18" / DN 450	STD	437.9 [15]	16,300 [574,600]	1,630 [57,460]	163 [5,750]	100
	80	409.3 [14.314]	14,300 [502,000]	1,430 [50,200]	143 [5,020]	100
20" / DN 500	XS	482.6 [15]	19,800 [697,700]	1,980 [69,770]	198 [6,980]	100
	80	455.6 [14.314]	17,700 [621,900]	1,770 [62,190]	177 [6,220]	100
24" / DN 600	XS	584.6 [15]	28,100 [989,700]	2,810 [98,970]	290 [10,240]	97
	80	547.7 [14.314]	24,600 [868,800]	2,460 [86,880]	255 [8,990]	97
30" / DN 750	30	730.2 [15]	42,300 [1,490,900]	4,230 [149,090]	453 [15,980]	94
	wt = 35	692 [14.314]	38,000 [1,338,900]	3,800 [133,890]	407 [14,350]	94

1) The actual flow range can vary depending on the application

Model FLC-UFL 4F - dimensions and weight					
Nominal size	Pressure rating	Length A in mm [inch]	Height B in mm [inch]	Height C in mm [inch]	Weight in kg [lb]
3" / DN 80	150	300 [11.8]	190 [7.5]	372 [14.6]	35 [77]
	300	350 [13.8]	210 [8.3]	382 [15]	36 [79]
	600	350 [13.8]	210 [8.3]	382 [15]	38 [84]
4" / DN 100	150	350 [13.8]	230 [9.1]	410 [16.1]	56 [123]
	300	350 [13.8]	255 [10]	422 [16.6]	60 [132]
	600	400 [15.7]	275 [10.8]	447 [17.6]	81 [179]
6" / DN 150	150	350 [13.8]	280 [11]	457 [18]	57 [126]
	300	400 [15.7]	320 [12.6]	477 [18.8]	96 [212]
	600	400 [15.7]	355 [14]	510 [20.1]	120 [265]
8" / DN 200	150	450 [17.7]	345 [13.6]	515 [20.3]	145 [320]
	300	500 [19.7]	380 [15]	532 [20.9]	175 [386]
	600	500 [19.7]	420 [16.5]	570 [22.4]	192 [423]
10" / DN 250	300	550 [21.7]	445 [17.5]	610 [24]	245 [540]
	600	550 [21.7]	510 [20.1]	640 [25.2]	295 [650]
12" / DN 300	300	600 [23.6]	520 [20.5]	675 [26.6]	285 [628]
	600	600 [23.6]	560 [22]	695 [27.4]	365 [805]
14" / DN 350	300	600 [23.6]	585 [23]	705 [27.8]	405 [893]
	600	600 [23.6]	605 [23.8]	730 [28.7]	435 [959]
16" / DN 400	300	700 [27.6]	650 [15]	755 [29.7]	620 [386]
	600	700 [27.6]	690 [16.5]	775 [30.5]	660 [423]
18" / DN 450	600	900 [35.4]	745 [29.3]	905 [35.6]	950 [2,095]
20" / DN 500	600	1,000 [39.4]	815 [32.1]	940 [37]	1,150 [2,536]
24" / DN 600	600	1,100 [43.3]	940 [37]	1,010 [39.8]	1,500 [3,308]
30" / DN 750	600	1,300 [51.2]	1,130 [44.5]	1,220 [48]	2,450 [5,402]

Model FLC-UFL 4F Duo

Description

The model FLC-UFL 4F Duo consists of two fully independent systems:

- A model FLC-UFL 4F with four ultrasonic paths for the main measurement
- A model FLC-UFL 3 or FLC-UFL 4F for the secondary measurement and extended diagnostics functions, enabling condition-based maintenance

Furthermore, systems with model FLC-UFL 4F Duo deliver a lot of information for condition monitoring of the entire measuring system.

Features

- Flow meter for custody transfer measurements with extended condition-based maintenance functions
- Ultrasonic paths at different pipe positions
- Two independent, accurate fiscal flow measurements in a single flow case
- Available from a size of 8" and in pressure ratings up to 900
- Extensive inputs and outputs, including optional pressure and temperature sensors, for PTZ calculation
- Extensive diagnostics information, delivered from specialised software
- Cost-effective solution for redundant measurements which are required for monitoring and verification

- Compact space-saving package
- Tested to fulfil the international standards for custody transfer measurements, e.g. AGA-9 and OIML R137 (class 0.5)
- Patented broadband continuous-wave technology
- Very low power consumption in operation
- Robust, high-efficiency, all-metal sensors
- Tools for the removal and replacement of sensors under pressure are available, suitable for pressures up to 153 bar [2,250 psi]

International approvals

- OIML R137-1 and -2-certified (class 0.5)
- AGA-9-compliant

Possible selections, model FLC-UFL 4F Duo

Configuration	Measuring instrument 1	Measuring instrument 2
Option 1	Model FLC-UFL 4F	Model FLC-UFL 3
Option 2	Model FLC-UFL 4F	Model FLC-UFL 4F

Model FLC-UFL 4F Duo with two independent sets of ultrasonic paths at different pipe positions:

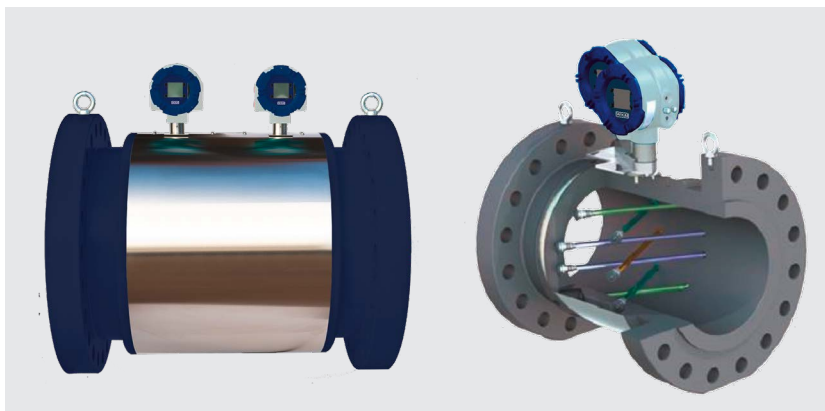

Model FLC-UFL 4F Duo - flow ranges ¹⁾						
Nominal size ANSI [“] / DIN [DN]	Schedule	Inner diameter in mm [inch]	Flow in m ³ /h [cf/h]			Turndown ratio
			Q _{max}	Q _t	Q _{min}	
8" / DN 200	40	202.7 [7.981]	3,490 [123,100]	349 [12,310]	35 [1,240]	100
	80	193.7 [7.625]	3,190 [112,370]	319 [11,237]	32 [1,130]	100
10" / DN 250	40	254.5 [10.02]	5,500 [194,100]	550 [19,410]	55 [1,950]	100
	80	238.2 [9.376]	4,900 [169,900]	490 [16,990]	49 [1,700]	100
12" / DN 300	STD	304.7 [11.938]	7,900 [278,200]	790 [27,820]	79 [2,790]	100
	80	289 [11.376]	7,100 [250,200]	710 [25,020]	71 [2,510]	100
14" / DN 350	STD	336.5 [13.126]	9,700 [339,200]	970 [33,920]	97 [3,400]	100
	80	317.5 [12.5]	8,600 [302,000]	860 [30,200]	86 [3,020]	100
16" / DN 400	STD	387.3 [15]	12,800 [449,500]	1,280 [44,950]	128 [4,500]	100
	80	363.5 [14.314]	11,300 [395,900]	1,130 [39,590]	113 [3,960]	100
18" / DN 450	STD	437.9 [15]	16,300 [574,600]	1,630 [57,460]	163 [5,750]	100
	80	409.3 [14.314]	14,300 [502,000]	1,430 [50,200]	143 [5,020]	100
20" / DN 500	XS	482.6 [15]	19,800 [697,700]	1,980 [69,770]	198 [6,980]	100
	80	455.6 [14.314]	17,700 [621,900]	1,770 [62,190]	177 [6,220]	100
24" / DN 600	XS	584.6 [15]	28,100 [989,700]	2,810 [98,970]	290 [10,240]	97
	80	547.7 [14.314]	24,600 [868,800]	2,460 [86,880]	255 [8,990]	97
30" / DN 750	30	730.2 [15]	42,300 [1,490,900]	4,230 [149,090]	453 [15,980]	94
	wt = 35	692 [14.314]	38,000 [1,338,900]	3,800 [133,890]	407 [14,350]	94

1) The actual flow range can vary depending on the application

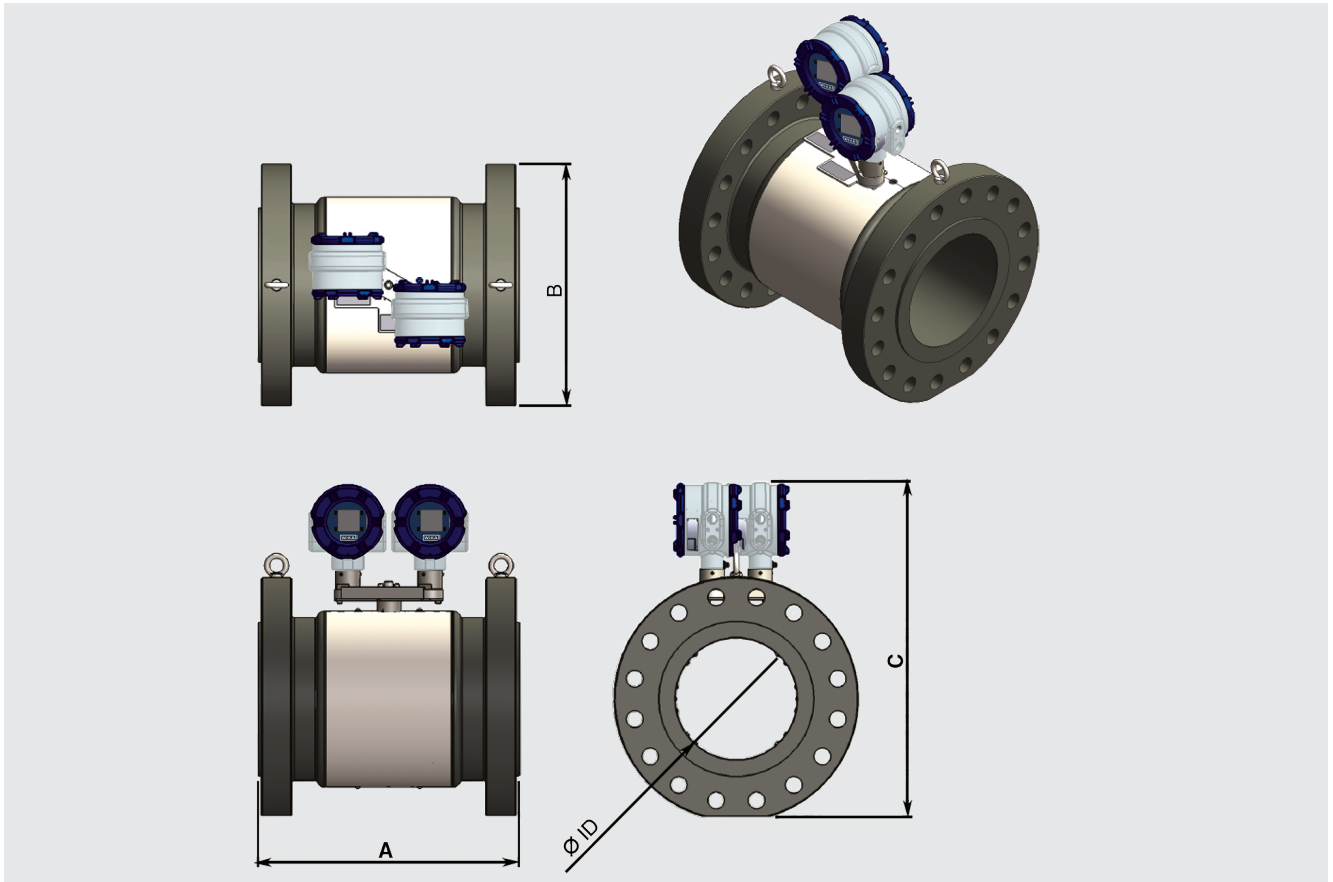

Dimensions, model FLC-UFL 4F Duo



Model FLC-UFL 4F Duo - dimensions and weight

Nominal size (ID)	Pressure rating	Length A in mm [inch]	Width B in mm [inch]	Height C in mm [inch]	Weight in kg [lb]
8" / DN 200	300	600 [23.6]	380 [15]	560 [22]	200 [496]
	600	600 [23.6]	420 [16.5]	600 [23.6]	225 [551]
10" / DN 250	300	600 [23.6]	445 [17.5]	640 [25.2]	265 [662]
	600	600 [23.6]	510 [20.1]	680 [26.8]	315 [750]
12" / DN 300	300	600 [23.6]	520 [20.5]	700 [27.6]	305 [805]
	600	600 [23.6]	560 [22]	720 [28.3]	385 [926]
14" / DN 350	300	600 [23.6]	585 [23]	635 [25]	425 [937]
	600	600 [23.6]	605 [23.8]	655 [25.8]	485 [1,069]
16" / DN 400	300	700 [27.6]	650 [15]	690 [22]	640 [441]
	600	700 [27.6]	690 [16.5]	710 [23.6]	680 [496]
18" / DN 450	600	900 [35.4]	745 [29.3]	905 [35.6]	950 [2,095]
20" / DN 500	600	1,000 [39.4]	815 [32.1]	940 [37]	1,150 [2,536]
24" / DN 600	600	1,100 [43.3]	940 [37]	1,010 [39.8]	1,500 [3,308]
30" / DN 750	600	1,300 [51.2]	1,130 [44.5]	1,220 [48]	2,450 [5,402]

Approvals

Logo	Description	Country
	EU declaration of conformity	European Union
	Measuring instrument directive (MID)	
	ATEX directive (option)	
	IECEX (option)	International
Custody transfer		
-	International Organization for Legal Metrology (OIML)	International
-	Measuring instrument directive (MID)	European Union

© 03/2021 WIKA Alexander Wiegand SE & Co. KG, all rights reserved.
 The specifications given in this document represent the state of engineering at the time of publishing.
 We reserve the right to make modifications to the specifications and materials.

