

TEMPERATURE

Electronic Temperature Transducers
Electronic Temperature Switches



switch

measure

control

Barksdale
Control Products GmbH

Index

Introduction	The Products 4
	General 5
	The Sensor Element 9
	Design 10
	Long Term Stability 10
	Response Time 10
	Explanations 11
	Conversion Chart 13
Standards and Approvals	14
Overview Temperature Sensors and Temperature Switches	15
<hr/>	
Types	
Electronic Temperature Transducer	Type UTA 3
	Description / Technical Data 19
	Dimensions / Electrical Connection 20
	Order Number Code 20
Electronic Temperature Switch	Type UTS 2
Single Temperatur Switch	Description / Technical Data 21
	Dimensions / Electrical Connection 22
	Order Number Code 22
Electronic Temperature Switches - DigiSwitch Series	Type TempSwitch 2000
Single / Dual Temperatur Switch	Description / Technical Data 23
	Dimensions / Electrical Connection 24
	Order Number Code 24
Dual Temperatur Switch	Type UTS 7
	Description / Technical Data 25
	Dimensions / Electrical Connection 26
	Order Number Code 26
Temperature Trip Amplifier with 4 Relay Outputs	Type UTS 3
	Description / Technical Data 27
	Dimensions / Electrical Connection 28
	Order Number Code 28
Temperature Switch with 4 Relay Outputs	Type UTS 4
	Description / Technical Data 29
	Dimensions / Electrical Connection 30
	Order Number Code 30

03 / 02 KTE-ENG 02/1

Barksdale Electronic Temperature Transducers / Switches

Specifications are subject to changes without notice.

Index

Temperature Sensor

Type UTF 3

Description / Technical Data	31
Dimensions / Electrical Connection	32
Order Number Code	32

Accessories

Conduits, thermal conductive paste	33
Certificates	33
Electrical plugs, power supplies	33

Information

Catalog overview / Fax order form	34
---	----

03 / 02 KTE-ENG 02/1

Barksdale Electronic Temperature Transducers / Switches

Specifications are subject to changes without notice.

Introduction

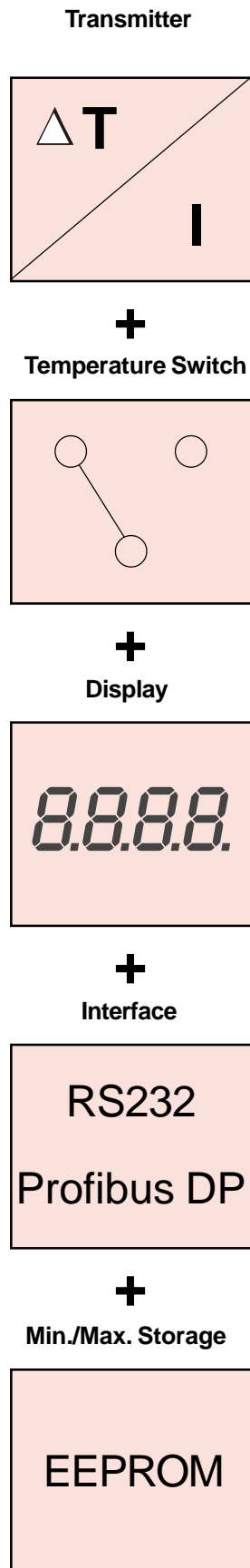

The Products

Our wide range of electronic temperature switches and temperature transducers offers a variety of switching functions from simple single-transistor output to microprocessor-controlled switches with four set points, analog output and even digital communications.

Different technologies and measuring principles let you choose from temperature measuring ranges from -30 °C to +150 °C and accuracy classes from 0,2% to 1%.

The main applications for our product range are determined by our DigiSwitch series, a trip amplifier with temperature switch and digital display in one compact housing.

Hydraulics and pneumatics, energy and environmental industry, heating and air-conditioning as well as chemical and pharmaceutical industry are some of the most important applications.

Electronic temperature switches and temperature transducers are particularly applicable in cases where the classic mechanical temperature switches do not offer enough accuracy, life span or functions as required by modern manufacturing technologies.

Leakages and leakage return lines, large hysteresis are no longer applicable to the closed measuring system of the electronic temperature switch.

Set points are adjustable by using an integrated LED or LCD digital display. Both set point and reactivation point are adjustable over the whole measuring range.

In addition to our individual components we offer a whole series of measuring instruments for your specific tasks. Just contact us.

Important:

Specifications are subject to modification at any time without prior notice.

03 / 02 KTE-ENG 02/1

Barksdale Electronic Temperature Transducers / Switches

Specifications are subject to changes without notice.

Introduction

General

The Barksdale electronic temperature switches are easy to install and operate, and provide a variety of functions and operating capabilities.

The UTS 2 features with its internal analog data acquisition of 0...2 V DC and comparator switching threshold with semiconductor output. All other Barksdale electronic switches are equipped with micro-controllers providing a variety of functions.

The analog temperature sensor input is amplified and digitized in an A/D-converter. A minimum 10 bit processor is used in the UTS 3 / UAS 3, 12 bit in the UTS 4 / UTS 7.

The multifunctional digital displays indicate the actual system temperature, functions and switching values, all controlled through the keypad. In the event of malfunction, error messages are also displayed.

The latest generation of the UTS 7 is equipped with a Dot-Matrix display which provide alphanumeric read outs.

In addition to the electronic temperature switches with micro-controllers we also design software for many special functions. Other solutions are available on request.

Set Point - Reactuation Point - Adjustment

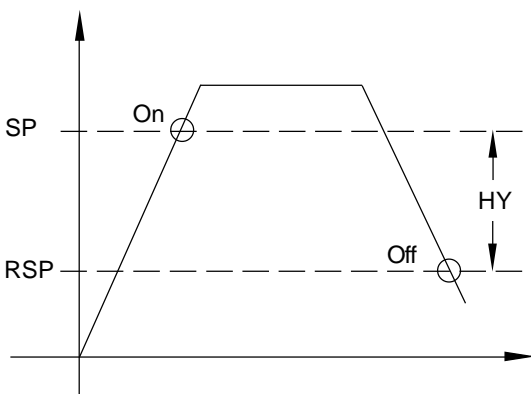

- SP = Switching Point
- HY = Hysteresis / Deadband
- RSP = Reactuation Point (Switching Point minus Hysteresis / Deadband)

With its internal analog comparator circuit, the set point for the UTS 2 can be adjusted with a potentiometer, either with system temperature, or, with a digital voltmeter (requires adaptor between the plug connectors).

The reactuation point in the UTS 2 results from the hysteresis*) which is factory set on 15% of the set point. Other values are possible but must be indicated when ordering. The order must also specify the switching function for increasing or decreasing pressure.

All other temperature switches and trip amplifiers in this catalogue are equipped with microcontrollers where set point and reactuation point are adjusted separately for each switching output.

Switches with four relay outputs feature keypad adjustment of set point and reactuation point. Switches with two outputs (UTS 7 / TempSwitch 2000) are adjusted by selecting the menu dialog with the M-(mode) pushbutton and arrow pushbutton.

*) Hysteresis, or deadband, is the difference between set point and reactuation point.

03 / 02 KTE-ENG 02/1

Barksdale Electronic Temperature Transducers / Switches

Specifications are subject to changes without notice.

Introduction

Switching Function

Decreasing or Increasing Temperature

All temperature switches in this catalog (except UTS 2) can be configured at the keypad for increasing or decreasing set points. A setting for „increasing“ will have hysteresis below the set point; a setting „decreasing“ will have hysteresis above the set point.

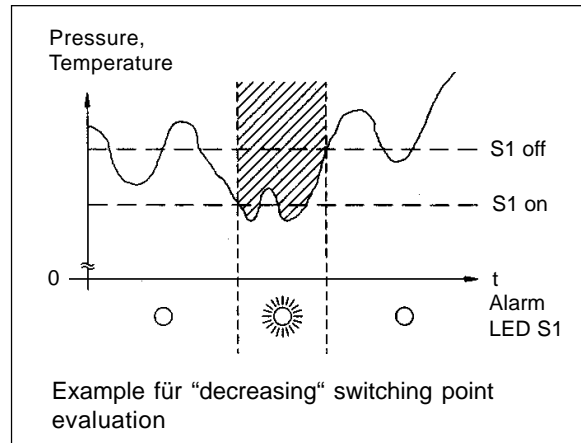
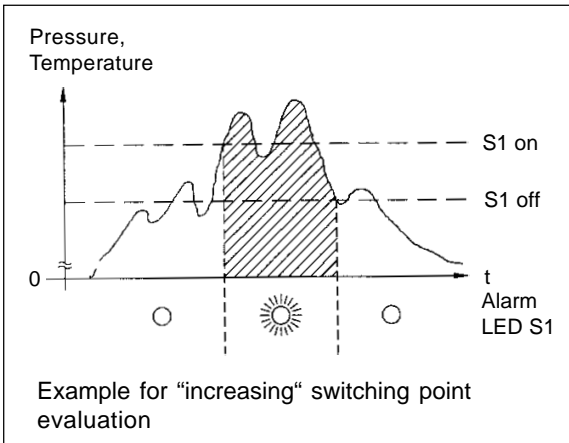

Standard- or Windows Technique

All switches (except UTS 2) offer two completely different switching modes:

- **Standard version:** The switching output switches between two set points like a two step controller
- **Window technique version:** Only one relay output is activated when the actual values are above or below the adjusted ON - OFF set points or measuring band.

This window technique is useful e. g. to actuate an alarm when the actual value is outside or within a required zone.

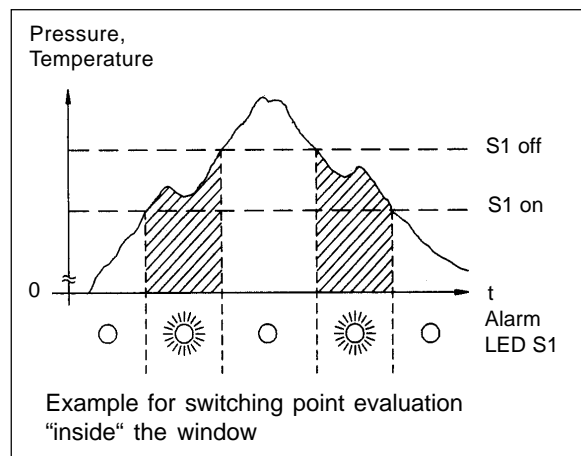
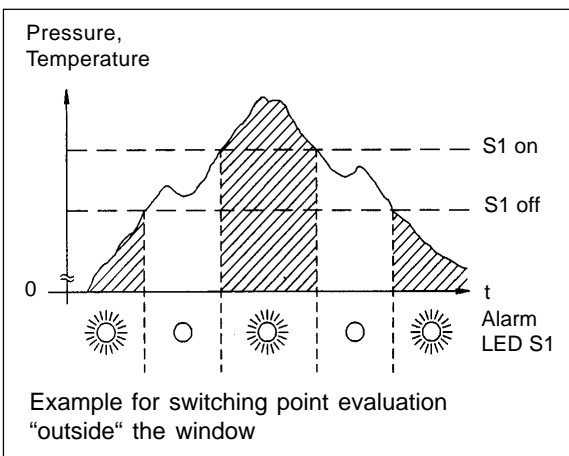

Introduction

Inversion of Switching Point

All microprocessor controlled switches offer the possibility to switch the already wired switching contact output by software from HLFS (= normally open / NO) to LLFS (normally closed / NC).

NOTE: As long as the power supply is activated the switching output operates in the desired HLFS (NO) or LLFS (NC) mode. Without voltage supply the relay coil is not longer energized and the contacts return to the basic position resp. the switching output is dead.

LEDs located between the S1 / ON and S 1 / OFF keys behind the front foil are not effected by the HLFS and LLFS change. These LEDs are influenced by the values of ON and OFF and the measured temperature. The LED illuminates at increasing pressure (input signal) if S1 / OFF is adjusted below the value of S1 / ON.

Or vice versa: The LED illuminates at decreasing pressure (input signal) if the value of S1 / OFF is adjusted higher then the value of S1 / ON.

Or vice versa: The LED illuminates at decreasing pressure (input signal) if the value of S1 / OFF is adjusted higher then the value of S1 / ON.

To prevent unnecessary switching at pulsating temperature all switches (except UTS 2) provide a delay function, seperately and in steps programmable.

This time delay operates with the same time in switch-on and switch-off function and is selectable individually for each switching output.

Switching Element

As instruments become smaller and more compact the switching elements have to be miniaturized also. Therefore the switches with four relay outputs and the electronic trip amplifiers are equipped with potential free SPDT contacts. They can be used alternatively as NO or NC contact.

Our single and dual temperature switches have electronic solid state outputs which can operate as NO or NC contact. In the UTS 2 single switch these functions are made by wire bridges. In the UTS 7 and TempSwitch 2000 dual switch, the functions are configured via the keypad.

The switching outputs of the UTS 7 and TempSwitch 2000 are designed as pnp-open collector as state of the art now for modern control systems. The outputs of the UTS 2 can be configured (polarity pnp or npn) at any time (Fig. 1 and 2) by a wire jumper bridge in the connector.

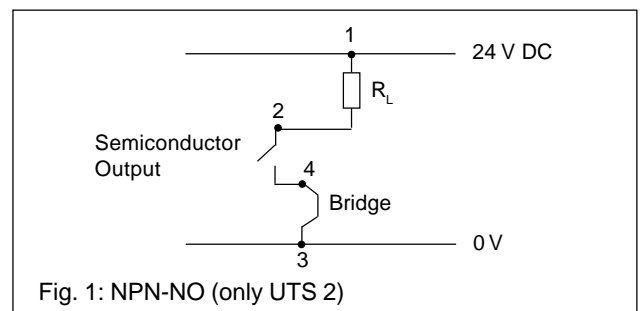
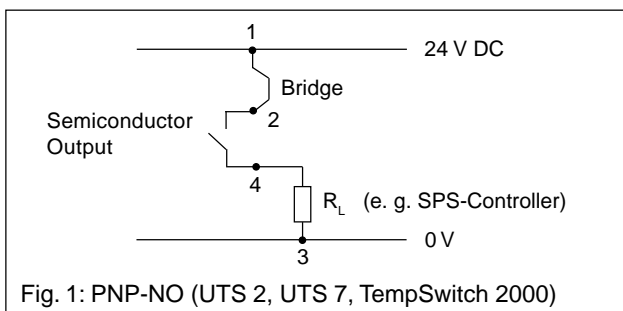

Introduction

Time Delay

To prevent unnecessary switching at pulsating pressures all switches (except UTS 2) provide a delay function, separately and in steps programmable.

This time delay operates with the same time in switch-on and switch-off function and is selectable individually for each switching output.

The UTS 7 provides additional, individual delays for display and analog output.

Keypad Lock

As soon as all operating parameters (set points, time delays etc.) are entered into the memory access for manipulating can be locked out. This is necessary to prevent unintended or unauthorized tampering. Reading the values on the display is possible at any time.

All 4 channel temperature switches can be locked via keyboard codes (software lock) or via wire bridge.

The UTS 7 and TempSwitch 2000 can be locked only via keypad code. The security of the system is guaranteed and failures caused by tampering are prevented.

Introduction

The Sensor Element

The basic principle

The basic principle of temperature measurement uses the effect that the electronic resistance of metal varies according to its temperature. In the simplest case, a measuring wire which is exposed to the temperature can serve as a sensor element.

When integrated into a measuring connection (e.g. Wheatston´s measuring bridge) the change in resistance indicates a direct measure for a temperature-related output signal.

In industrial measuring technology, platinum (Pt) has proved itself ideal in its application as a sensor element due to the stability and consistency of its electronic values and its good chemical resistance.

The sensor in all the appliances described below is a platinum multiplier type Pt 100.

The value of resistance at 0 °C is defined as 100 Ohm. According to DIN regulation IEC 751, the allowable variance from this value is laid down as follows:

Allowable variance in °C
for class A: $\pm (0,15 + 0,002 [T])$

Allowable variance in °C
for class B: $\pm (0,3 + 0,005 [T])$
([T] is temperature in °C)

Abbreviation for the sensor element/resistance material		Pt100 (Platinum)			
Resistance and allowable variance					
Temp. measured in °C	Basic value ohm	Class A		Class B	
		ohm	°C	ohm	°C
-200	18,49	+/- 2,4	+/-0,55	+/-0,56	+/-1,3
-100	60,25	+/-0,14	+/-0,35	+/-0,32	+/-0,8
0	100	+/-0,06	+/-0,15	+/-0,12	+/-0,3
100	138,5	+/-0,13	+/-0,35	+/-0,3	+/-0,8
200	175,84	+/-0,20	+/-0,55	+/-0,48	+/-1,3
300	212,02	+/-0,27	+/-0,75	+/-0,64	+/-1,8
400	247,04	+/-0,33	+/-0,95	+/-0,79	+/-2,3
500	280,9	+/-0,38	+/-1,15	+/-0,93	+/-2,8
600	313,59	+/-0,43	+/-1,35	+/-1,06	+/-3,3
650	329,51	+/-0,46	+/-1,45	+/-1,13	+/-3,6

Introduction

Design

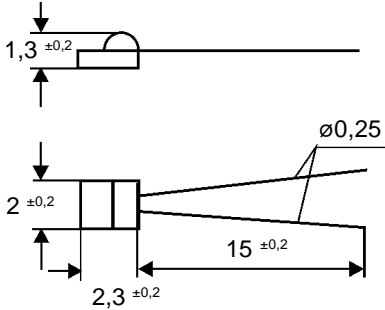

Long term stability

Reaction times

Temperature measuring

Platinum multipliers are attached to a carrier in the form of a wire or a thin layer of metal to register the mean value of the temperature affecting their total length.

This construction, when in contact with precious metal leads, is vibration-proof and can be used in extreme operating conditions. In general, this construction is not used for temperature measurement unless it is insulated in some way. The Pt 100 is used as a component in resistance thermometers for arc horns, gauge slides or light plastic-sheathed cable.

Compared to other sensor elements, platinum multipliers have good long-term stability.

(typical e. g.: variation in resistance from < 0,02 % to >1.000 h)

For the multiplier in question, the following reaction times have been documented:

Reaction time in seconds		Reaction time in seconds	
in water at a flow speed $v = 0,2 \text{ m/s}$		in air at a flow speed $v = 1 \text{ m/s}$	
50 % T_{max}	90 % T_{max}	50 % T_{max}	90 % T_{max}
0,05 sec.	0,2 sec.	4 sec.	10 sec.

The reaction time for the appliances depends on the mass of the temperature sensor in this catalog, where the measuring resistance is located. Further details on request.

Temperature measurement is based on the measurement of resistance obtained via the measuring bridge (wheatstone bridge , fig. 1).

We differentiate between a 2 conductor or a 3 conductor circuit (see fig. 2 and 3)

The 4 conductor circuit includes a current - voltage - measurement (see fig. 4).

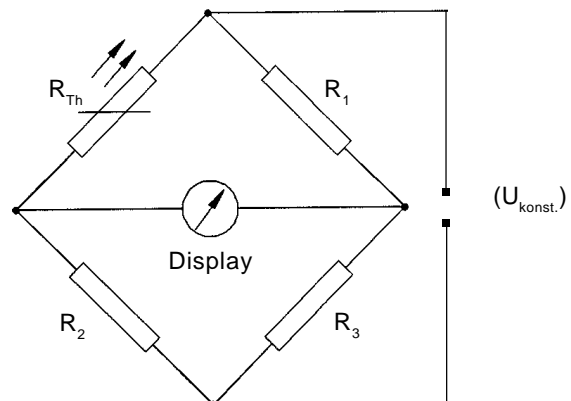

Fig. 1

Introduction

2-wire circuit

Two wires lead from the resistance thermometer to the measuring transducer (differential amplifier). The electricity is conducted via these leads, the voltage tap taking place simultaneously. This means that the specific resistance (R_L) and the multiplier are within the same range and the resistance affects the measurement with its amount and changes (T_{amb}). The 2 conductor circuit is mainly utilised when the measurement does not need to comply with high standards of accuracy or where minimal lead lengths are used. In practice, resistance thermometers with integrated measuring transmitter ('head transmitter') are constructed according to the following principle:

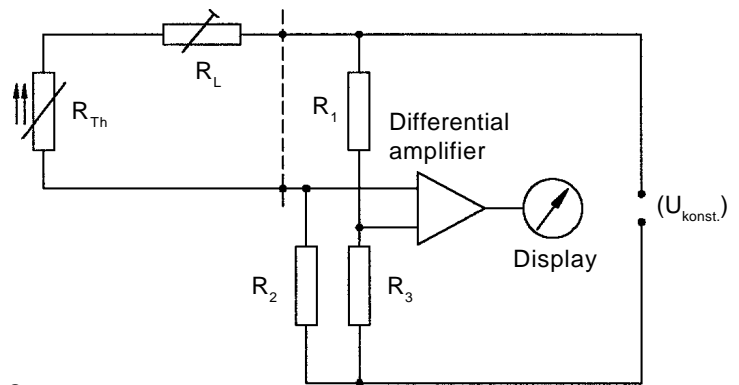

Fig. 2

3-wire circuit

Three wires lead from the resistance thermometer to the measuring transmitter (differential amplifier). The power lead and a voltage tap are combined and directly attached to a connecting point on the multiplier. The loading resistor (R_L) is integrated into the measuring bridge with balance and variations caused by temperature changes (T_{amb}) are compensated. The maximum length of lead is approximately 10 m.

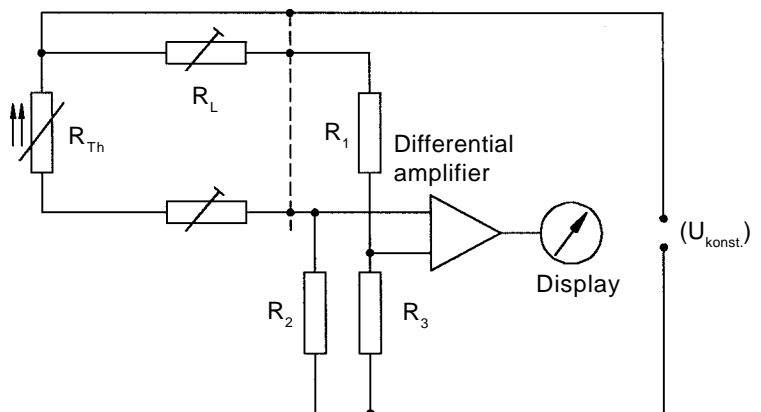

Fig. 3

Introduction

4-wire circuit

Four wires lead from the resistance thermometer to the measuring transmitter (high drain amplifier). A stabilized power supply, independent of the resistance of the circuit, feeds the multiplier. The voltage drop is syphoned off via the voltage path, a second pair of conductors, and so independent from the (RL) and non-volatile.

This observed form of circuit provides a high level of measuring accuracy.

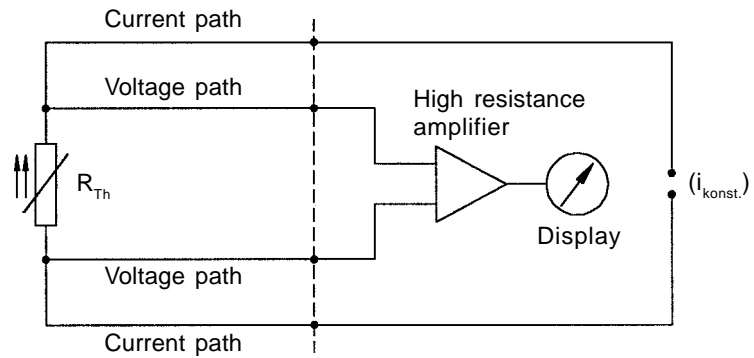

Fig. 4

Earthing of resistance thermometers

Fig. 5.2: 3-wire circuit

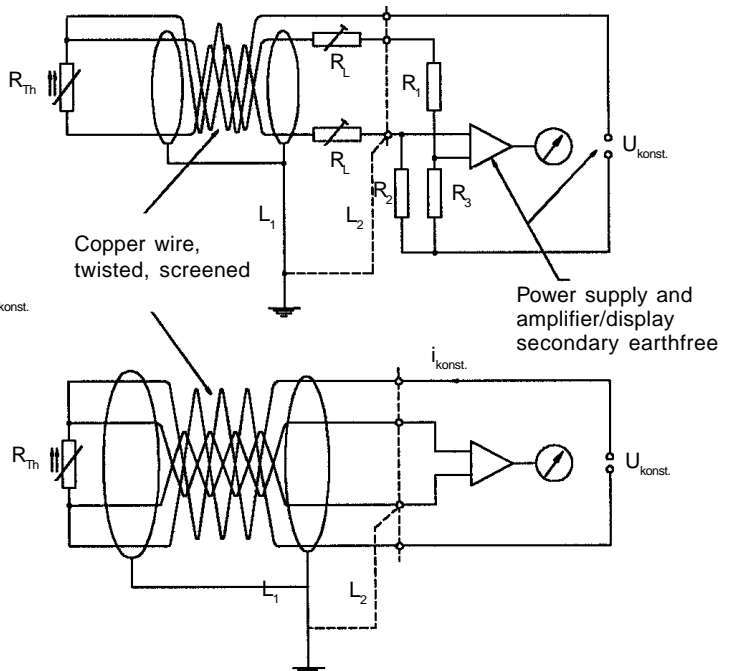
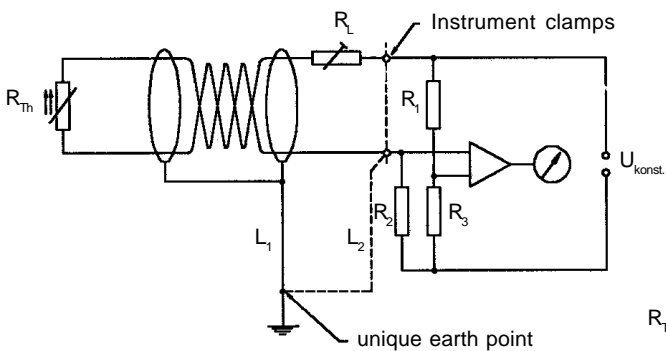

Fig. 5.3: 4-wire circuit

Fig. 5.1: 2-wire circuit



Introduction

Temperature Conversion Table

Conversion: $^{\circ}\text{F} = (^{\circ}\text{C} \times 9/5) + 32$
 $^{\circ}\text{C} = (^{\circ}\text{F} - 32) \times 5 / 9$

$^{\circ}\text{C}$	\Leftrightarrow	$^{\circ}\text{F}$	$^{\circ}\text{C}$	\Leftrightarrow	$^{\circ}\text{F}$	$^{\circ}\text{C}$	\Leftrightarrow	$^{\circ}\text{F}$
- 45.6	- 50	- 58	79.4	175	347	204	400	752
- 42.8	- 45	- 49	82.2	180	356	207	405	761
- 40.0	- 40	- 40	85.0	185	365	210	410	770
- 37.2	- 35	- 31	87.8	190	374	213	415	779
- 34.4	- 30	- 22	90.6	195	383	216	420	788
- 31.7	- 25	- 13	93.3	200	392	218	425	797
- 28.9	- 20	- 4	96.1	205	401	221	430	806
- 26.1	- 15	5	98.9	210	410	224	435	815
- 23.3	- 10	14	102	215	419	227	440	824
- 20.6	- 5	23	104	220	428	229	445	833
- 17.8	0	32	107	225	437	232	450	842
- 15.0	5	41	110	230	446	235	455	851
- 12.2	10	50	113	235	455	238	460	860
- 9.4	15	59	115	240	464	241	465	869
- 6.7	20	68	118	245	473	243	470	878
- 3.9	25	77	121	250	482	246	475	887
- 1.1	30	86	124	255	491	249	480	896
1.7	35	95	127	260	500	252	485	905
4.4	40	104	129	265	509	254	490	914
7.2	45	113	132	270	518	257	495	923
10.0	50	122	135	275	527	260	500	932
12.8	55	131	138	280	536	263	505	941
15.6	60	140	141	285	545	266	510	950
18.3	65	149	143	290	554	268	515	959
21.1	70	158	146	295	563	271	520	968
23.9	75	167	149	300	572	274	525	977
26.7	80	176	152	305	581	277	530	986
29.4	85	185	154	310	590	279	535	995
32.2	90	194	157	315	599	282	540	1004
35.0	95	203	160	320	608	285	545	1013
37.8	100	212	163	325	617	288	550	1022
40.6	105	221	166	330	626	291	555	1031
43.3	110	230	168	335	635	293	560	1040
46.1	115	239	171	340	644	296	565	1049
48.9	120	248	174	345	653	299	570	1058
51.7	125	257	177	350	662	302	575	1067
54.4	130	266	179	355	671	304	580	1076
57.2	135	275	182	360	680	307	585	1085
60.0	140	284	185	365	689	310	590	1094
62.8	145	293	188	370	698	313	595	1103
65.6	150	302	191	375	707	316	600	1112
68.3	155	311	193	380	716	318	605	1121
71.1	160	320	196	385	725	321	610	1130
73.9	165	329	199	390	734	324	615	1139
76.7	170	338	202	395	743	327	620	1148

The middle column shows the temperature in $^{\circ}\text{C}$ or $^{\circ}\text{F}$, the required temperature can then be located on the left or right hand side of it. (e. g.: $0^{\circ}\text{C} \Leftrightarrow 32^{\circ}\text{F}$ resp. $0^{\circ}\text{F} \Leftrightarrow 17,8^{\circ}\text{C}$)

03 / 02 KTE-ENG 02/1

Barksdale Electronic Temperature Transducers / Switches

Specifications are subject to changes without notice.

Standards and Approvals

Quality according to standards

Barksdale Control Products electronic temperature measurement instruments are designed, manufactured and tested according to the actual standards and specifications of IEC-publications, EN-standards or DIN VDE-specifications including country-specific standards and factory standards. New products as well as updated products fulfill the requirements of the latest European and international standard layouts.

Barksdale Control Products GmbH's quality control and quality assurance management is ISO 9001 certified and guarantees a high level of quality for development, design and production.

Electromagnetical Compatibility

According to EG-guideline (89/336 EWG) referring to electro-magnetical compatibility (EMV-guideline) electric and electronic instruments must meet specified requirements to assure satisfying function in their electro-magnetical environment. These requirements are specified in following standards and specifications:

Electromagnetic Emission:

Electronic noise emission in process technology industry are tested according to standard EN 55011.

Electromagnetic Interference:

IEC 1000-4-1 / EN 61000-4-1

Electro-magnetical compatibility of measuring-, controlling and monitoring-instruments in the process technology industry

IEC 1000-4-2 / EN 61000-4-2

Interference immunity against discharge of static electricity (ESD).

IEC 1000-4-3 / EN 61000-4-3

Interference immunity against electro-magnetical fields (Hf-field).

IEC 1000-4-4 / EN 61000-4-4

Interference immunity against quick transient interferences (Burst).

IEC 1000-4-6 / ENV 50141

Interference immunity against induced conducted interferences.

Test degree acc. to EN 50082-2

Basic standard interference immunity

Standard	Interference	Test degree
IEC 1000-4-2 / EN 61000-4-2	ESD	4 kV CD / 8 kV AD
IEC 1000-4-3 / EN 61000-4-3	HF emitted	10 V/m; 80 ... 1000 MHz
IEC 1000-4-4 / EN 61000-4-4	Burst	2 kV coupling pliers
IEC 1000-4-6 / EN ENV 50141	HF conducted	10 V; 0,15 ... 80 MHz

Overview



03 / 02 KTE-ENG 02/1

Barksdale Electronic Temperature Transducers / Switches

Specifications are subject to changes without notice.

Model	Temperature Transducer Type UTA 3	Single Temperature Switch Type UTS 2
Measuring Element	Pt 100 (Class B) according to DIN IEC 751	Pt 100 (Class B) according to DIN IEC 751
Features	robust temperature sensor, compact construction	single temperature switch, compact construction
Applications	OEM-applications, hydraulics and pneumatics, test beds	OEM-applications, hydraulics and pneumatics, mobile hydraulics
Measuring Ranges	0...+100 °C to -30...+150 °C	0...+100 °C to -30...+150 °C
Linearity Error	max. <0,5% f. s.	max.<0,5% f. s.
Display	- - -	Switch status by 1 LED, red
Output Signals	4...20 mA (2-wire) 0...10 V DC (3-wire)	- - -
Switching Outputs	- - -	1 solid state output pnp-NO/NC, free adjustable by potentiometer or voltmeter
Hysteresis/Deadband	- - -	factory set 15 % of adjusted set point (optional 2 % to 50%)
Options	GL-approval	on request
Temp. Drift of Zero Signal and Outp. Span (Ref. 20°C)	<0,1% / 10 K from -10...+80 °C	<0,1% / 10 K from -10...+80 °C
Operating Temp.-Range	-25...+80 °C	-10...+70 °C
Media Temperature Range	-30...+150 °C	-30...+150 °C
Process Connection	G 1/4, male, stainless steel	G 1/4, male, stainless steel
Protection Class	IP67 with PG / IP65 with plug	IP67 with PG / IP65 with plug
Electrical Connection	Plug 5-pin M 12 x 1, cable gland PG7 incl. 1,5 m cable	Plug 5-pin M 12 x 1, cable gland PG7 incl. 1,5 m cable
Supply	8...30 V DC	10...30 V DC
Catalog Page	19	21

Overview



Model	Electronic Single / Dual Temperature Switch TempSwitch 2000	Dual Temperature Switch Type UTS 7
Measuring Element	Pt 100 (Class B) according to DIN IEC 751	Pt 100 (Class B) according to DIN IEC 751
Features	shock- and vibration proof, single or dual temperature switch, microcontroller and self monitoring, DESINA®-conformity	shock- and vibration proof dual temperature switch, microcontroller and self monitoring
Applications	Hydraulics and pneumatics (e. g. presses), lubrication monitoring, machine industry, automobile industry, machine tools/injection moulding machines	hydraulics and pneumatics, process- and chemical industry, machine industry
Measuring Ranges	0...+100 °C to -30...+150 °C	0...+100 °C to -30...+150 °C
Linearity Error	max.<0,5% f. s.	max.<0,5% f. s.
Display	3-digit 7-segment LED-display, 10 mm height, red	4-digit DOT-Matrix LED-display, 8 x 5 mm height, green or 4-digit LCD-display, 10 mm height
Output Signals	- - -	4...20 mA (scalable) 0...10 V DC (scalable)
Switching Outputs	1 resp. 2 solid state outputs pnp-NO/NC, (programmable), adjustable time delay 0...10 s	2 solid state outputs pnp-NO/NC, (programmable), adjustable time delay 0...10 s
Hysteresis/Deadband	seperate adjustable set-/actuation points	seperate adjustable set-/actuation points
Options	On request	RS232 interface, Profibus-DP interface
Temp. Drift of Zero Signal and Outp. Span (Ref. 20°C)	<0,1% / 10 K from -10...+80 °C	<0,1% / 10 K from -10...+80 °C
Operating Temp.-Range	-10...+70 °C	-10...+70 °C
Media Temperature Range	-30...+150 °C	-30...+150 °C
Process Connection	G 1/4 male	G 1/4, stainl. steel., G 1/2, G 3/8, male
Protection Class	IP67	IP67 with PG / IP65 with plug
Electrical Connection	Plug 4-pin M 12 x 1, DESINA®-conformity	Plug 5-pin M 12 x 1, cable gland PG7 incl. 1.5 m cable
Supply	12...32 V DC	18...32 V DC
Catalog Page	23	25

03 / 02 KTE-ENG 02/1

Barksdale Electronic Temperature Transducers / Switches

Specifications are subject to changes without notice.

Overview

03 / 02 KTE-ENG 02/1



Barksdale Electronic Temperature Transducers / Switches
Specifications are subject to changes without notice.

Model	Temperature Trip Amplifier Type UTS 3	Temperature Switch Type UTS 4
Measuring Element	Integrated trip amplifier with 10-bit analog-digital-converter, microcontroller and self monitoring, with integrated sensor supply (Sensor Pt 100), 4-wire	Pt 100 (Class B) according to DIN IEC 751
Features	rugged universal digital display with analog input/output and 4 relay outputs, microcontrolled	universal digital 4-fold temperature switch, microcontroller and self monitoring
Applications	OEM-applications in hydraulics and pneumatics, heavy industrie, automobile industrie	Precision test beds, air conditioning, hydraulics and pneumatics, process- and power plant industry
Measuring Ranges	0...100 °C to -30...+150 °C	0...+100 °C to -30...+150 °C
Linearity Error	max. <0,2% f. s.	max. <0,5% f. s.
Display	4-digit 7-segment LED-display, height 10 mm, red	4-digit 7-segment LCD-display, height 12 mm
Output Signals	4...20 mA 0...10 V DC	4...20 mA 0...10 V DC
Switching Outputs	4 x switch outputs with SPDT relays adjustable time delay 16 ms...10 s	4 x switch outputs with SPDT relays adjustable time delay 16 ms...10 s
Hysteresis/Deadband	seperate adjustable set-/actuation points	seperate adjustable set-/actuation points
Options	on request	RS232, binary inputs
Temp. Drift of Zero Signal and Outp. Span (Ref. 20°C)	<0,1% / 10 K from -10 °C...+80 °C	<0,1% / 10 K from -10 °C...+80 °C
Operating Temp.-Range	-10...+70 °C	-10...+70 °C
Media Temperature Range	- - -	-30...+100 °C
Process Connection	- - -	G 3/8, G 1/2, brass or stainless steel
Protection Class	IP65	IP65
Electrical Connection	plug connector 14-pin, 1 x PG 13,5 side entry, sensor connection 5-pin plug M 12 x 1	screw terminal 2 x 12 pin, 2 x PG 13,5 side entry
Supply	15...30 V DC	15...30 V DC
Catalog Page	27	29

Overview



Model	Temperature Sensor Type UTF 3
Measuring Element	Pt 100 (Class B) according to DIN IEC 751
Features	stainless steel, compact construction
Applications	machine- and process industry, air-conditioning, marine and ship building industry
Measuring Ranges	-30...+150 °C
Linearity Error	Sensing resistor Pt 100 (Class B)
Display	- - -
Output Signals	Pt 100-signal, 4-wire
Switching Outputs	- - -
Hysteresis/Deadband	- - -
Options	GL-approval
Temp. Drift of Zero Signal and Outp. Span (Ref. 20°C)	- - -
Operating Temp.-Range	-30...+100 °C
Media Temperature Range	-30...+150 °C
Process Connection	G 1/4, male, stainless steel
Protection Class	IP67 with PG / IP65 with plug
Electrical Connection	Plug 5-pin M 12 x 1 (90° elbow or straight), cable gland PG7/PG9 incl. 1,5 m cable
Supply	- - -
Catalog Page	31

Type UTA 3

**Stainless steel,
accuracy 0,5% f. s.**

Features

Zero and range adjustable,
rugged and compact stainless steel construction,
protection class IP65 resp. IP67,
also with GL (Germanischer Lloyd) shipbuilding approval

Measuring Ranges

0... +100 °C bis -30...+150 °C

Applications

- Hydraulics and pneumatics
- Machine- and process industry
- Test beds
- Marine applications



Technical data

Sensor	: Pt 100 (Class B), DIN IEC 751
Materials	
Wetted Parts	: Stainless steel W.-Nr. 1.4571
Housing (Electronics)	: Stainless steel W.-Nr. 1.4571
Seals	: Viton, EPDM
Proof Pressure	: 600 bar
Protection class	: IP65 plug, IP67 cable
Process connection	: G 1/4 male, nut across flats 19 mm
Dimensions	: ø 24 mm x 86 mm (without electrical plug)
Weight	: 130 g
Measuring ranges	: -30 °C...+100 °C, -30 °C...+150 °C 0 °C...+100 °C, 0 °C...+150 °C
Linearity error	: < ± 0,5% f. s.
Time constant	: appr. 40 s
Electrical connection	: PG7 incl. 1,5 m cable plug M 12 x 1; 5-pin, electrical plugs please order seperately (see „Accessories“) cable gland PG9 incl. 5 m ship cable (with GL-approval)

Sensor length	: 17 mm (Standard) 25, 50, 100, 150, 200, 250 mm
Sensor diameter	: 6 mm
Hysteresis	: ≤ ± 0,1 % f. s.
Repeatability	: ≤ ± 0,1 % f. s.
Temperature range	: -30 °C...+150 °C (Media) -25 °C...+ 80 °C (Electronics) -40 °C...+100 °C (Storage)
Power supply	: 10...30 V DC unregulated, max. 10 % residual ripple, reversed polarity protected
Output signals	: 4...20 mA (2-wire) 0...10 V DC (3-wire)
Power consumption	: max. 30 mA at current output max. 10 mA at load
Load	: ≤ (U _b -8V) / 0,02 A
Adjustment range	: Zero and span up to ± 5% (after removing protection cap nut across flats 15)
Accessories	: conduit, electrical plugs

03 / 02 KTE-ENG 02/1

Barksdale Electronic Temperature Transducers / Switches

Specifications are subject to changes without notice.

Type UTA 3

Dimensions (in mm)

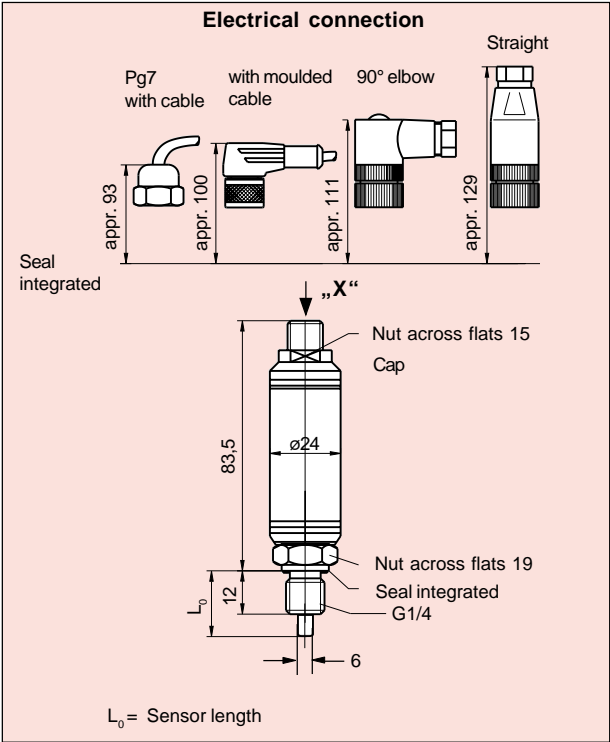

Electrical connection

Connection	Current output 4-20 mA (2-wire)			Voltage output 0-10V (3-wire)		
	Plug	Cable	GL-Cable	Plug	Cable	GL-Cable
+ Supply	1	brown	blue 1	1	brown	blue 1
- Supply	2	white	blue 2	2	blue	blue 2
+ Signal	---			3	white	white 1
- Signal	---			---		

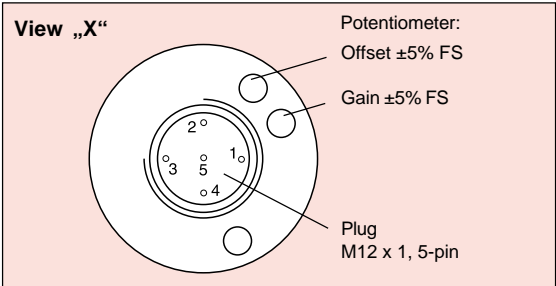

Order number example

Type	Series	Process-seal	Temperature meas.-range	Output-signal	Electrical connection	Sensor length	Options
UTA 3	63-02	1	03	1	2	01	

Your order number

UTA 3	63-02						
-------	-------	--	--	--	--	--	--

Process seal	Temp. meas.-range	Output signal	Electrical connection	Sensor length	Options
(1) Viton - Standard e. g. hydraulic oil	(02) -30... +100°C (04) -30... +150°C (08) 0... +100°C (10) 0... +150°C	(1) 4...20 mA 2-wire	(1) Cable gland PG 9 incl. 1,5 m cable	(from sealing edge)	(GL) GL-approval
(3) EPDM - e. g. brake fluid	(00) Special ranges	(2) 0...10 V 3-wire	(2) Plug 4-pin, M12 x 1 (8) Cable gland PG 9 incl. 1,5 m ship cable (with GL-approval) (0) Special connection	(01) 17 mm (Standard) (02) 25 mm (03) 50 mm (04) 100 mm (05) 150 mm (06) 200 mm (07) 250 mm (00) Special length	

03 / 02 KTE-ENG 02/1

Barksdale Electronic Temperature Transducers / Switches

Specifications are subject to changes without notice.

Type UTS 2

**For temperature monitoring,
with solid state output without digital display,
accuracy class 0,5 % f. s.**

Features

Set point without temperature default, adjustable with potentiometer, rugged and compact stainless steel construction, switching hysteresis factory set, high switching accuracy, protection class IP65 resp. IP67, high shock- and vibration stability.

Measuring Ranges

0... +100 °C to -30...+150 °C

Applications

OEM-applications in hydraulics and pneumatics, mobile hydraulics and engineering, air conditioning control



Technical data

Sensor	: Pt 100 (Class B), DIN IEC 751
Materials	
Wetted Parts	: Stainless steel W.-Nr. 1.4571
Housing (Electronics)	: Stainless steel W.-Nr. 1.4571
Seals	: Viton, EPDM
Proof Pressure	: 600 bar
Protection class	: IP65 plug, IP67 cable
Process connection	: G 1/4 male, nut across flats 19 mm
Dimensions	: ø 24 mm x 86 mm (without electrical plug)
Weight	: 150 g
Measuring ranges	: -30 °C...+100 °C, -30 °C...+150 °C 0 °C...+100 °C, 0 °C...+150 °C
Linearity error	: < ± 0,5% f. s.
Time constant	: appr. 40 s
Electrical connection	: PG7 incl. 1,5 m cable plug M 12 x 1; 5-pin electrical plugs please order separately (see „Accessories“)
Sensor length	: 17 mm (Standard) 25, 50, 100, 150, 200, 250 mm
Sensor diameter	: 6 mm

Repeatability	: ≤ ± 0,1 % f. s.
Temperature range	: -30 °C...+150 °C (Media) -25 °C...+ 80 °C (Electronics) -40 °C...+100 °C (Storage)
Power supply	: 10...30 V DC unregulated, max. 10 % residual ripple, reversed polarity protected
Display (Operation)	: LED green
Power consumption	: appr. 10 mA at Ub=24 V DC (without load)
Solid state output	
Adjustment range	: 5%... 125% f. s. 2000 mV = E.W. (plug pin 5)
Hysteresis	: 15% (± 2%) of set point factory set (on request 2%... 50% of set point)
Switching frequency	: max. 1 kHz
Switching output	
- external selectable	: pnp - open collector
- max. 500 mA	: short circuit-proof
Display	: LED red for activated set point
Accessories	: - Adaptor for set point adjustment, pluggable - conduit - electrical plugs

03 / 02 KTE-ENG 02/1

Barksdale Electronic Temperature Transducers / Switches

Specifications are subject to changes without notice.

Type UTS 2

Dimensions (in mm)

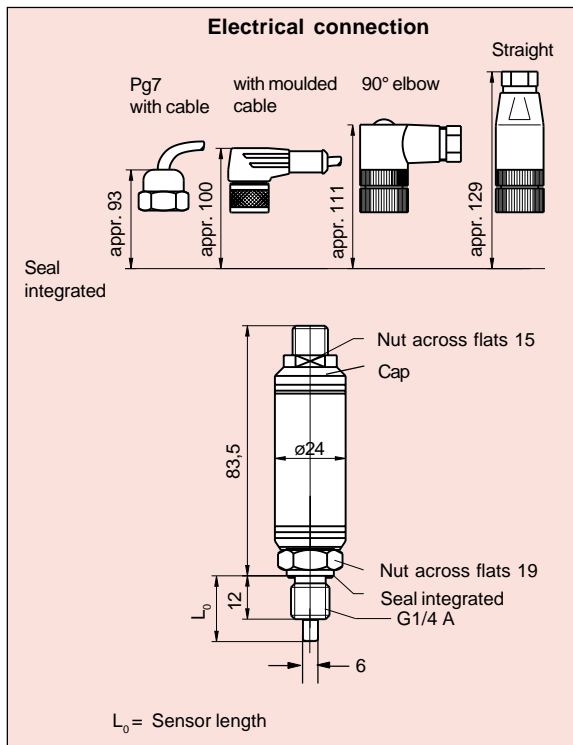

Electrical connection

Plug M 12 x 1 5-pin	PG7 w. cable LifYY11Y 5x0,25 mm ²	pnp NO/NC	Set point adjustment P _{nenn} = 2000 mV
Pin 1	brown	+Ub 10...30 V DC 1	+Ub 10...30 V DC 1
Pin 2	white	bridge 2	2
Pin 3	blue	0 V 3	0 V 3
Pin 4	black	R _L 4	R _L > 100kΩ 4
Pin 5	grey	5	5

Order number example

Type	Series	Process seal	Temperature meas.-range	Output signal Switching output	Electrical connection	Sensor length
UTS 2	64-02	1	03	1	3	01

Your order number

UTS 2	64-02					
-------	-------	--	--	--	--	--

Process seal	Temp.-meas.-ranges	Output signal	Electrical connection	Sensor length
(1) Viton - Standard e. g. hydraulic oil	(02) -30... +100°C (04) -30... +150°C (08) 0... +100°C (10) 0... +150°C	(1) solid state output pnp- (NO)	(1) Cable gland PG 9 incl. 1,5 m silicone cable	(from sealing edge)
(3) EPDM - e. g. brake fluid	(00) Special ranges	(2) solid state output pnp- (NC)	(2) Plug 4-pin, M12 x 1 (0) Special connection	(01) 17 mm (standard) (02) 25 mm (03) 50 mm (04) 100 mm (05) 150 mm (06) 200 mm (07) 250 mm (00) Special length

Accessories

Order number	Description
0499-003	Adaptor for set point adjustment, pluggable (only for electrical connection code 2)

03 / 02 KTE-ENG 02/1

Barksdale Electronic Temperature Transducers / Switches

Specifications are subject to changes without notice.

TempSwitch 2000

**Temperature control digital display,
2 solid state contacts,
accuracy class 0,5% f. s.**

Features

7-segment LED display, microprocessor controlled, self monitoring with error display, display rotatable around 330°, DESINA®-conformity (see also www.desina.de), all parameters are configured by keypad, tamper proof, keypad lock, rugged construction, vibration- and shock-proof, long term stability

Measuring Ranges

0...+100 °C to -30... +150 °C

Applications

Hydraulics and pneumatics (e. g. presses), lubrication monitoring, machine industry, automobile industry, machine tools, injection moulding machines

Technical Data

Sensor Element	: PT100-element (Class B)
Materials :	
Wetted Parts	: Stainless steel 1.4435 (SS 316L)
Housing (Electronics)	: Aluminum die-cast
Seals	: Viton
Proof Pressure	: 600 bar
Operating Elements	: 3 easy response pushbuttons
Protection Class	: IP67
Process Connection	: G1/4 male
Dimensions (Housing)	: 36 x 130 mm (without electrical plug), rotatable housing for switch adjustment after mounting
Weight	: appr. 200 g with 17 mm sensor length
Measuring Ranges	: -30...+100 °C, -30... +150 °C 0...+100 °C, 0... +150 °C
Linearity Error	: ±0,5% f. s. at 25 °C
Time Constant	: Appr. 40 s
A/D-Converter	
Resolution	: 10 bit (1024 steps per meas. span)
Scanning Rate	: 100/s (for peak value memory)
Electrical Connection	: Plug M 12 x 1, 4-pin, DESINA®-conforming
Sensor Length	: 17 mm (Standard), 25, 50, 100, 150, 200, 250 mm



Sensor Diameter	: 6 mm
Repeatability	: ±0,1% f. s.
Temperature Range	: -30 °C ... +150 °C (Media) -10 °C ... + 70 °C (Electronics) -30 °C ... + 80 °C (Storage)
Power Supply	: 12 ... 32 V DC unregulated, max. 10 % residual ripple, reversed polarity protected
Digital Display	: 3-digit LED display, 7-segment, height 10 mm, red
Display Range	: -99 ... 999
Display Rate	: 20/s
Display Unit	: °C, °F - adjustable
Error Display	: LED yellow and alphanumeric display (Diagnosis function acc. DESINA®)
Power Consumption	: appr. 50 mA (without load)
Switching Output(s)	
Switching Function (adjustable)	: Normally open/ normally closed, standard-/windows-mode
Adjustment Range	: 0%... 125% f. s.
Hysteresis	: 0%... 125% f. s.
Diagnosis Function	: SP2 (DESINA®-version)
Switching Frequency	: max. 100 Hz
Contact Rating	: max. 500 mA, short circuit-proof
Delay	: 0,0... 9,9 s adjustable
Status Display(s)	: LED(s) green for activated switching point
Options	: electrical plug with screw terminal

TempSwitch 2000

Dimensions (in mm)

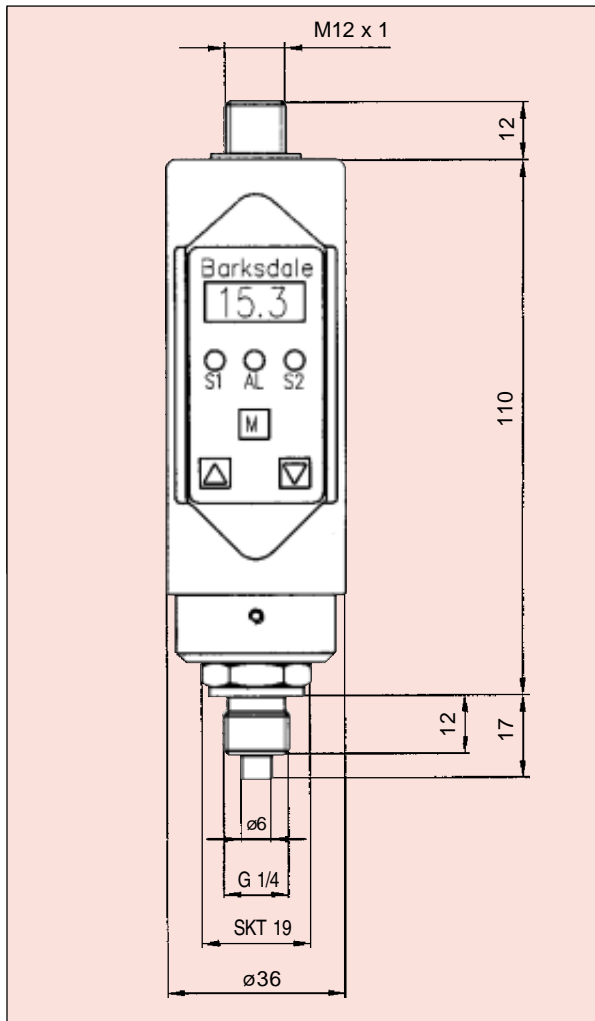

Connection Chart

Plug M 12 x 1, 4-pin	Version with 1 switching output	Version with 2 switching outputs (DESINA®-model)
Pin 1	+Ub (12 .. 32 V / DC)	+Ub (12 .. 32 V / DC)
Pin 2	-	SP2 (0,5 A max.)
Pin 3	0V	0V
Pin 4	SP1 (0,5 A max.)	SP1 (0,5 A max.)

Connection Scheme

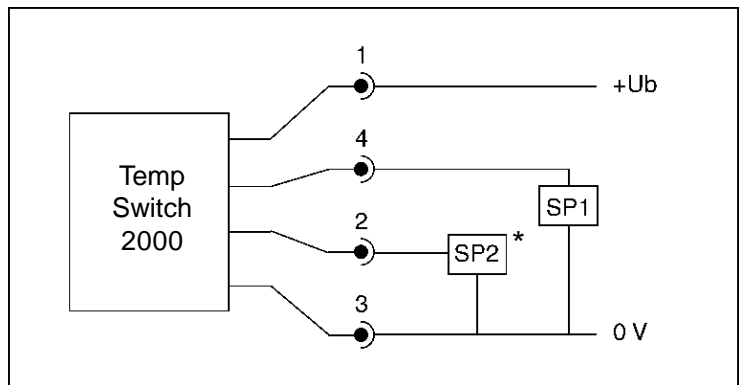

* SP2 = Diagnosis output (DESINA®-version)

Order number example

Type	Series	Temperature range	Output signal switching output	Electrical connection	Process connection	Sensor length
UTS 7	64-08	08	1	2	1	01

Your order number

UTS 7						
-------	--	--	--	--	--	--

Series	Temp.-range	Output signal	Electrical connection	Connection	Sensor length
(64-08) 3-digit 7-segment- LED-display, red	(02) -30...+100 °C (04) -30...+150 °C (08) 0...+100 °C (10) 0...+150 °C (00) Special range	(1) 1 solid state output PNP (2) 2 solid state outputs PNP	(2) Plug 4-pin, M12 x 1	(1) G 1/4 male	(from sealing edge, in mm) (01) 17 (Stand.) (02) 25 (03) 50 (04) 100 (05) 150 (06) 200 (07) 250 (00) Special length

03 / 02 KTE-ENG 02/1

Barksdale Electronic Temperature Transducers / Switches

Specifications are subject to changes without notice.

Type UTS 7

For temperature monitoring with digital display, 2 solid state outputs and 1 analog output, accuracy class 0,5 % f. s.

Features

Alphanumeric 4-digit LCD or LED-Dot-Matrix-display, display rotatable around 330°, microcontroller and self monitoring with error output, all parameters programmable via keypad, adjustable keypad lock, different access levels, rugged stainless steel construction.

Measuring Ranges

0... +100 °C to -30...+150 °C

Applications

Hydraulics and pneumatics, process- and chemical industry, machine industry, machine tools

Technical data

Sensor element	: Pt 100 (Class B)
Materials:	
Housing	: stainless steel W.-Nr. 1.4571
Process seal	: Viton standard, EPDM
Proof Pressure	: 600 bar
Operating elements	: 3 easy response pushbuttons at the frontside, all parameters programmable, adjustable keypad lock
Protection class	: IP65 with plug, IP67 with cable gland
Process connection	: G1/4 Standard, G3/8, G1/2, male
Housing dimensions	: 131 mm (without electrical plug) rotatable housing for adjusting display after installation
Weight	: appr. 350 g with 17 mm sensor length
Measuring ranges	: -30 °C...+100 °C, -30 °C...+150 °C 0 °C...+100 °C, 0 °C...+150 °C
Linearity error	: < ± 0,5% f. s.
Time constant	: appr. 40 s
Data aquisition	: microcontroller and self monitoring with error output
Resolution	: 12 bit (4096 steps)
Scanning rate	: 100 Hz
Electrical connection	: cable gland PG7 with 1,5m cable or plug M 12 x 1, electrical plugs please order seperately (see „Accessories“), 4- or 5-pin
Sensor length	: 17 mm (standard) 25, 50, 100, 150, 200, 250 mm



Sensor diameter	: 6 mm
Repeatability	: ± 0,1 % f. s.
Temperature range	: -30 °C...+150 °C (Media) -10 °C...+ 70 °C (Electronics) -30 °C...+80 °C (Storage)
Power supply	: 10...30 V DC unregulated, max. 10% residual ripple, reversed polarity protected
Operating display	: - 4-digit LCD-display, 10 mm height - 4-digit LED-Dot-Matrix-display, green, height 5 mm with decimal point
Display rate	: 5/s
Display unit	: °C
Delay	: 0,0...9,9s adjustable (for display damping)
Brightness	: 20...100% - adjustable
Error Display	: LED red and alphanumeric display
Power Consumption	: appr. 40 mA at $U_b = 24$ V DC (without load)
Output signal	: 4... 20 mA o. 0...10 V DC, short circuit-proof
Delay	: 0,0...9,9 s adjustable
Max. load	: max. $R_I = (U_b - 12V) / 20mA$, 600 Ohm at 24 V DC
Solid state output(s)	: 1 or 2 pnp-Open-Collector solid state switching outputs
Adjustment range	: 0... 125% f. s.
Hysteresis	: 0... 125% f. s.
Switching frequency	: 100/s
Delay time	: 0,0...9,9 s - adjustable
Max. constant current	: 500 mA
Display	: 2 x LED green for activated set point
Option	: serial interface RS232 with Profibus-DP (Slave) or Windows user surface
Accessories	: conduit, electrical plugs

Type UTS 7

Dimensions (in mm)

Connection chart

03 / 02 KTE-ENG 02/1

Barksdale Electronic Temperature Transducers / Switches

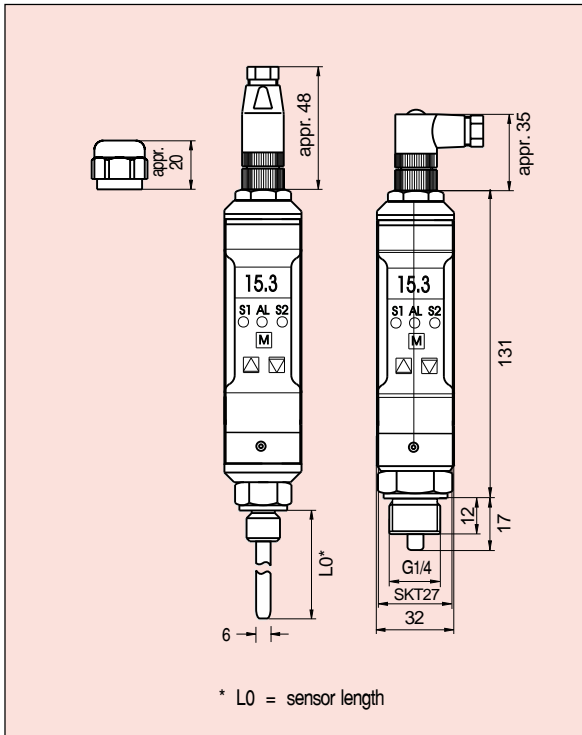

* L0 = sensor length

Plug	PG9 with cable LifYY11Y 4 / 5x0,25mm ²	Version with 1 switching output	Version with 2 switching outputs	Version with 1 switching output and 1 analog output	Version with 2 switching outputs and 1 analog output
Pin 1	brown	+Ub 18 .. 32 V/DC	+Ub 18 .. 32 V/DC	+Ub 18 .. 32 V/DC	+Ub 18 .. 32 V/DC
Pin 2	white	-	SP2 0,5A max.	analog 4-20mA/ 0-10VDC	analog 4-20mA/ 0-10VDC
Pin 3	blue	0V	0V	0V	0V
Pin 4	black	SP1 0,5A max.	SP1 0,5A max.	SP1 0,5A max.	SP1 0,5A max.
Pin 5	grey	-	-	-	SP2 0,5A max.

Connection chart (plug 2) for interface

plug M 12 x 1, 5-pin	Model with RS232 (V24) interface	Model with Profibus-DP interface
Pin 1	RXD	END_A
Pin 2	TXD	DAT_A
Pin 3	GND	END_B
Pin 4	- - -	DAT_B
Pin 5	- - -	GND

Order number example

Type	Series	Temperature range	Output signal switching output	Electrical connection	Process connection	Sensor length
UTS 7	64-07	08	1	1	3	01

Your order number

UTS 7						
-------	--	--	--	--	--	--

Specifications are subject to changes without notice.

Series	Temp.-range	Output signal	Electrical connection	Connection	Sensor length	
(64-07) LED-Dot-Matrix-display	(02) -30...+100 °C	(1) 1 solid state output PNP	(1) Cable gland PG 9 incl. 1,5 m cable	(1) G 1/4 A	(from sealing edge)	
	(04) -30...+150 °C	(2) 2 solid state outputs PNP		(2) G 3/8 A		
	(08) 0...+100 °C	(3) 1 solid state output and 1 analog output 4...20 mA	(2) Plug 4-pin, M12 x 1	(3) G 1/2 A	(in mm)	
	(10) 0...+150 °C		(5) Plug 5-pin, M12 x 1			
(64-37) LCD 12-segment-display (no Profibus-DP possible)	(00) Special range	(4) 1 solid state output and 1 analog output 0...10V	(9) 2 Plugs 5-pin, M12 x 1, (for devices with interface)		(01) 17 (Standard)	
		(5) 2 solid state outputs and 1 analog output 4...20 mA			(02) 25	
		(6) 2 solid state outputs and 1 analog output 0...10V		(03) 50		
		(7) Profibus-DP and 2 switching outputs		(04) 100		
(8) RS232 interface and 2 switching outputs and 1 analog output 4...20 mA			(05) 150	(06) 200	(07) 250	(00) Special length

Type UTS 3

For temperature monitoring with external temperature sensors, digital display, 4 relay outputs and 1 analog output, accuracy class 0,5% f. s.

Features

4-digit 7-segment LED display, microcontroller, self monitoring, all parameters are configured by keypad, front cover with display turnable by 90° adjustable keypad lock

Measuring Ranges

0... +100 °C bis -30...+150 °C

Applications

OEM-applications, hydraulics and pneumatics, heavy industry, engineering, automobile industry

Technical data

Sensor input	: Resistance thermometer Pt 100 acc. DIN IEC 751 (e. g. temperature sensor Type UTF 3) in 2-, 3- or 4-wire (independent on wire resistance only in 4-wire operation)
Measuring current	: appr. 2 mA
Wire resistance	: max. 80 Ohm
Linearity	: according to DIN IEC 751 max. ±0,5% f. s. at 25 °C
Repeatability	: ±0,1% f. s.
Weight	: appr. 1080 g
Sensor connection	: plug 5-pin M 12 x 1 incl. electrical plug - straight for cable diameter 4...6 mm
Temperature range	: -30 °C...+150 °C (Media) (only for UTF 3, other sensors and and measuring ranges possible) -10 °C...+ 70 °C (Electronics) -30 °C...+ 80 °C (Storage)
A/D-converter:	
Resolution	: 10 bit (1024 steps per measuring span)
Scanning rate	: 500/s (for peak value memory)
Analog output :	
Current output	: 4... 20 mA
Load	: max. RL = (Ub - 12 V) / 20 mA RL = 600 Ohm bei Ub = 24 V/DC
Load influence	: 0,01%/100 Ohm
Limit frequency	: 1 kHz
Voltage output	: 0...10V
Rating	: max. 10 mA, short circuit-proof
Electrical connection	: Plug-in, terminal strip with 14 screws for 1,5 mm ² , AWG14 slots
Cable gland	: 1 x PG 13,5 side entry = standard 2 x PG 13,5 top entry = optional
Sensor connection	: Plug M 12 x 1, 5-pin, below



Housing:	
Dimensions	: 100 (W) x 135 (H) x 80 (D) mm
Material	: Aluminum cast G AL SI 12
Seal (Housing)	: Neoprene
Protection Class	: IP65 acc. to DIN 40050
Operating Elements	: Keypad w. easy response pushbuttons
Material	: Polyester
Power Supply	: 15 ... 30 V DC unregulated, max. 10 % residual ripple, reversed polarity protected, from 20 V DC supply power buffer up to 20 ms
Power Consumption	: ca. 200 mA
Fuse	: 500 mA/250V delayed action (5x20 mm) (Housing has to be opened)
Display	: 4-digit 7-segment LED, 10 mm height, red
Display range	: -30...+100 °C to 0...+150 °C
Display rate	: 4/s
Display unit	: °C
4 x Relay Output(s) - SPDT-Contacts	
Contact Rating	: max. 250 V AC / 120 V DC
Switching capacity	: max. 1250 VA / 120 W, 220 V/AC, 3 A, VDE 0660T.2
Constant current	: max. 5 A
Cycles	: 1 Mio. at 24 V DC/2 A
Switching Rate	: max. 20/s
Delay	: 16 ms...10 s adjustable
Operation Time	: 1 ms
Status Display	: 4 x LED red
Options	: Mounting bracket, vibration dampers, electrical plugs for separate sensors

Type UTS 3

Electrical connection

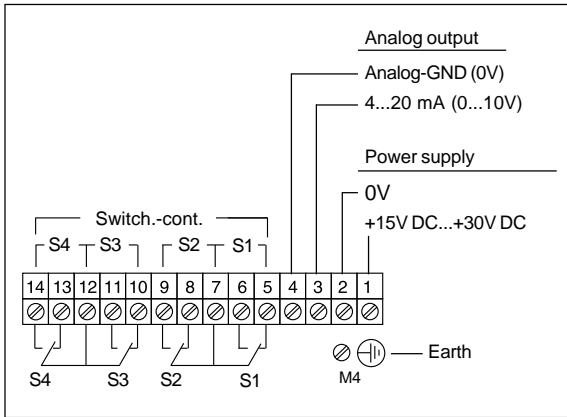

Dimensions (in mm)

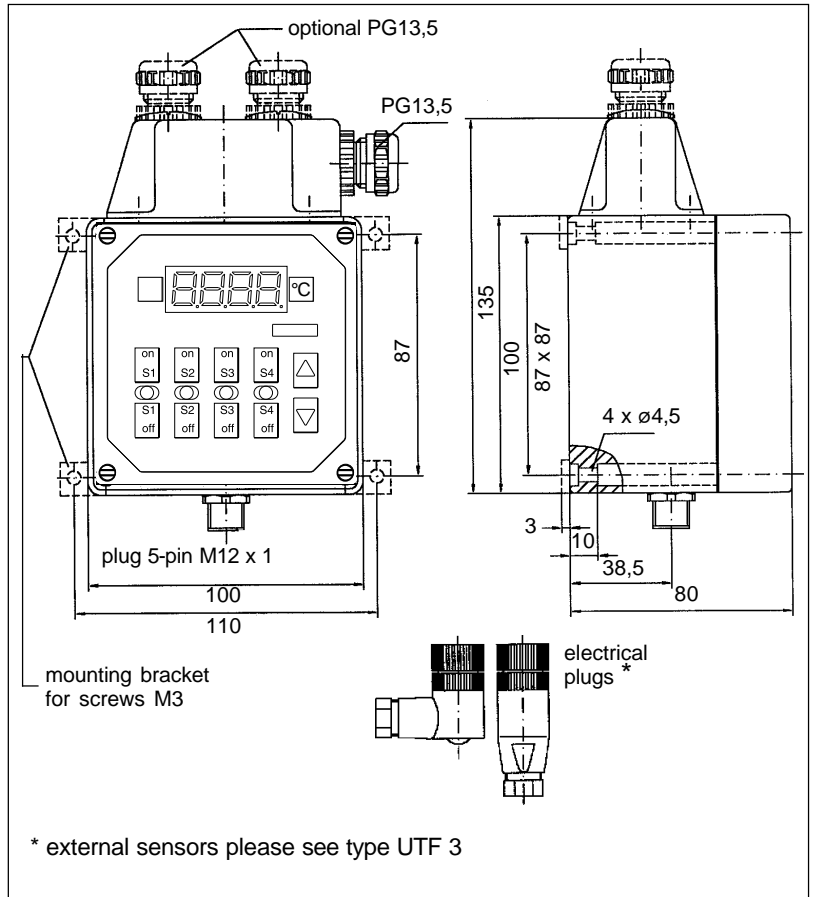

Sensor connection

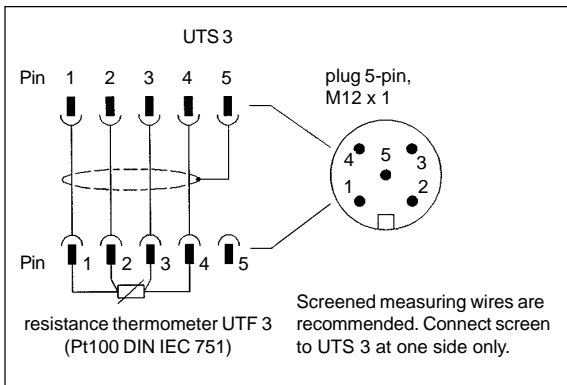

Order number example

Type	Series	Temperature meas.-range	Signal resolution	Output signal	Electr. sensor connection
UTS 3	64-03	08	1	1	4
UTS 3	64-03				

Temperature measuring ranges	Signal resolution	Output signal	Electr. sensor connection
(02) -30... +100°C	(1) 10-bit resolution - standard - (1024 steps)	(1) 4...20 mA	(4) Plug 5-pin
(04) -30... +150°C		(4) 0...10V	(0) Special connection
(08) 0... +100°C			
(10) 0... +150°C			
(00) Special ranges			

Accessories

Order number	Description
0613-016	Temperature sensor Type UTF 3 (Pt100 4-wire) see page 28
0099-001	Mounting brackets for wall mounting (1 set = 2 pcs.)
914-0107	Vibration damper (1 set = 4 pcs.)

03 / 02 KTE-ENG 02/1

Barksdale Electronic Temperature Transducers / Switches

Specifications are subject to changes without notice.

Type UTS 4

For temperature monitoring with integrated temperature sensor, digital display, accuracy class 0,5%

Features

4-digit 7-segment LCD display, microcontroller, self monitoring, all parameters are configured by keypad, high accuracy, quick scanning rate (2 ms), 4 switching outputs, 1 analog output, front cover with display rotatable by 90°

Measuring Ranges

0... +100 °C bis -30...+150 °C

Applications

Precision test beds, air conditioning, process industry, power plants

Technical data

Sensor	: Pt 100 (Class B), DIN IEC 751
Materials :	
Wetted parts	: Stainless steel W.-Nr. 1.4435 or brass
Housing (Electronics)	: Aluminum cast G AL SI 12
Seals	: Viton, EPDM
Keypad	: Polyester foil
Proof Pressure	: 600 bar
Operating elements	: Keypad with easy response pushbuttons
Protection class	: IP65
Process connection	: G 3/8, G 1/2, male, stainless steel or brass
Dimensions	: 100 (W) x 100 (H) x 80 (D) mm
Weight	: appr. 1010 g (Brass) appr. 1300 g (Stainless Steel)
Measuring ranges	: -30... +100 °C; -30... +150 °C; 0...+100 °C; 0...+150 °C;
Linearity error	: ± 0,5% f. s. at 25 °C
A/D-converter	
Resolution	: 12 bit (appr. 4096 steps p. meas. span)
Scanning Rate	: 500/s (for peak value memory)
Operating display	
: 4-digit 7-segment LCD display Height 12 mm, trend arrows	
Display range	: -5000... +5000
Display rate	: 4/s
Display damping	: 16 ms... 9,9 s adjustable
Sensor length	: 50 mm (standard) 100, 150, 200, 250 mm



Sensor diameter	: 6 mm
Electrical connection	: 2 x 12-pin screw terminals for cable max. 1,5 mm ² AWG14, 2 cable gland PG 13,5
Repeatability	: ± 0,1% f. s.
Temperature range	: -30 °C ... +150 °C (Media) -10 °C ... + 70 °C (Electronics) -30 °C ... + 80 °C (Storage)
Power supply	: 15... 30 V DC unregulated, max. 10 % residual ripple, reversed polarity protected
Power consumption	: appr. 150 mA at Ub = 24 V DC (without load)
Analog output	
Resolution	: 12 Bit
Damping	: 16 ms ... 9,9 s - adjustable
Current output	: 4... 20 mA
Load	: max. RI = (Ub-8V)/20 mA RI = 800 Ohm at Ub = 24 V DC
Voltage output	: 0... 10 V DC
Rating	: max. 10mA, short circuit-proof
Binary input	: 5... 30 V DC, Ri = 1,2 kOhm
4 x Relay output(s) - SPDT-Contacts	
Contact rating	: max. 120V DC / 250 V AC max. 120W / 1250 V AC
Cycles	: 1 Mio. at 24V DC / 2 A
Switching rate	: max. 20/s
Delay	: 16 ms... 9,9 s adjustable
Operation time	: 1 ms
Status display	: 4 x LED red
Options	: Mounting brackets, vibration dampers, conduit, RS232 interface

Type UTS 4

Dimensions (in mm)

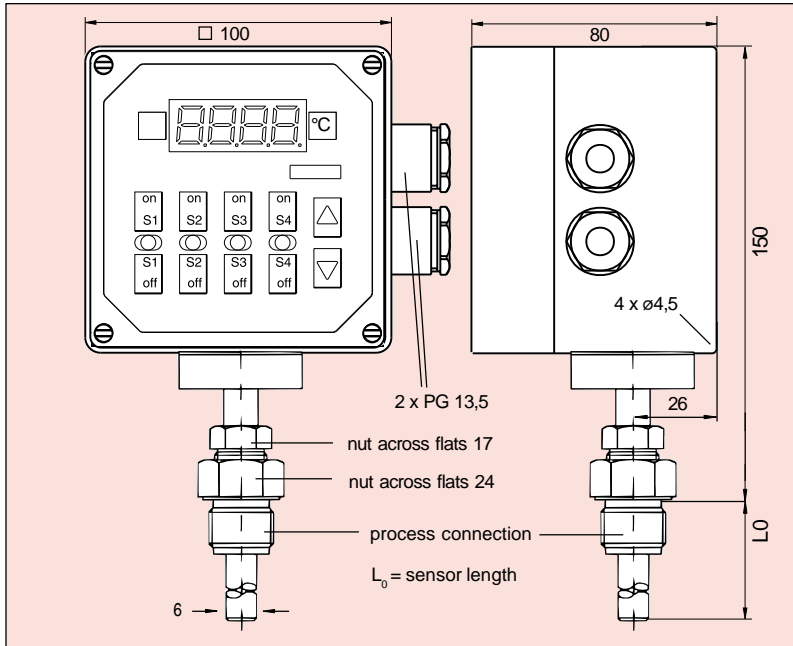

Electrical connection

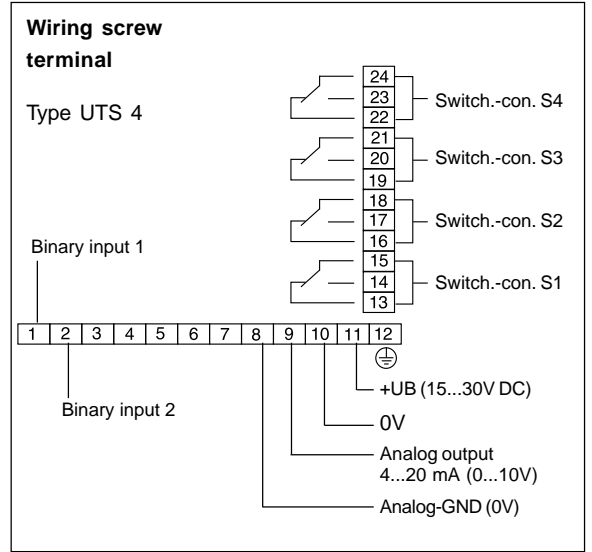

Order number example

Type	Series	Process seal	Temperature meas.-range	Signal resolution	Output signal	Digital interface	Process connection	Sensor length
UTS 4	62 -	1	08	12	1	0	03	10

Your order number

UTS 4	62 -							
-------	------	--	--	--	--	--	--	--

Process seal	Temp.-meas.-range	Signal resol.	Output signal	Dig. interface	Process connection	Sensor length
(1) Viton - Standard e.g. hydraulik oil	(02) -30... +100°C (04) -30... +150°C (08) 0... +100°C (10) 0... +150°C	(2) 12-bit-resolution (4096 steps)	(0) no analog output (1) 4... 20 mA (standard)	(0) without (1) RS232 (V24) serial interface	Material: brass (02) G 3/8 male (03) G 1/2 male Material: stainl. steel (12) G 3/8 male (13) G 1/2 male	(from sealing edge) (05) 50 mm (standard) (10) 100 mm (15) 150 mm (20) 200 mm (00) Special length
(3) EPDM - e.g. brake fluid,	(00) Special ranges		(4) 0... 10 V			

Accessories

Order number	Description
0099-001	Mounting brackets for wall mounting (1 set = 2 pcs.)
914-0107	Vibration dampers (1 set = 4 pcs.)

03 / 02 KTE-ENG 02/1

Barksdale Electronic Temperature Transducers / Switches

Specifications are subject to changes without notice.

Type UTF 3

For temperature monitoring with Pt 100-Sensor (Class B)

Features

Rugged and compact stainless steel construction, protection class IP65 resp. IP67, high shock- and vibration stability, also with GL (Germanischer Lloyd) shipbuilding approval

Measuring Ranges

-30...+150 °C

Applications

Machine industry, mobile hydraulics and environmental technology, air conditioning control, marine applications



Technical data

Sensor	: Sensing resistor Pt100 acc. to DIN IEC 751, (Class B, 4-wire)
Construction:	
Dimensions	: ø24 x 86 mm (without electrical plug)
Materials:	
Wetted parts	: stainless steel W.-Nr. (1.4571)
Housing	: stainless steel W.-Nr. (1.4571)
Proof Pressure	: 600 bar
Seal	: Viton (standard), EPDM
Process connection	: G 1/4 male, nut across flats 19 mm
Proof pressure	: max. 600 bar
Protection class	: IP65 plug, IP67 cable
Weight	: ca. 110 g
Measuring ranges	: -30 °C...+150 °C
Time constant	: appr. 40 s
Measuring current	: max. 5 mA

Electrical connection	: plug 5-pin M12 x 1 : cable gland PG7 incl. 1,5 m cable : cable gland PG9 incl. 5 m ship cable (with GL-approval) : electrical plugs please order seperately (see „Accessories“)
Sensor length	: 17 mm (standard) 25, 50, 100, 150, 200, 250 mm
Sensor diameter	: 6 mm
Accessories	: conduit, electrical plugs

03 / 02 KTE-ENG 02/1

Barksdale Electronic Temperature Transducers / Switches

Specifications are subject to changes without notice.

Type UTF 3

Dimensions (in mm)

Connection chart

03 / 02 KTE-ENG 02/1

Barksdale Electronic Temperature Transducers / Switches

Specifications are subject to changes without notice.

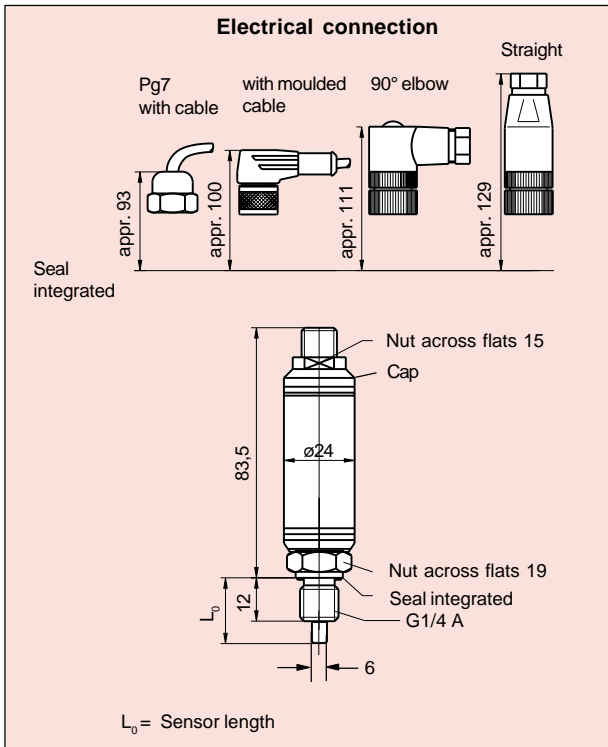

Pt100		PG7 with cable 4 x 0,25 mm ²	plug 5-pin	PG9 with ship cable
	Pin 1	white		white 1
	Pin 2	brown		white 2
	Pin 3	green		blue 1
	Pin 4	yellow		blue 2
		plug 5-pin, M 12 x 1		

Order number example

Type	Series	Temp.-sensor seal	Electrical connection	Process connection	Sensor length	Options
UTF 3	63-03	1	4	01	017	

Your order number

UTF 3	63-03					
-------	-------	--	--	--	--	--

Temperat.-sensor seal	Electrical connection	Process connection	Sensor length	Options
(1) Viton - Standard e. g. hydraulic oil	(1) Cable gland PG 7 incl. 1,5 m silicone cable, Tmax = 150°C	(01) G 1/4 male	(from sealing edge))	(GL) GL-approval
(3) EPDM - e. g. brake fluid	(4) Plug 5-pin, M 12 x 1 Tmax = 100 °C		(017) 17 mm (standard)	
	(8) Cable gland PG 9 incl. 1,5 m ship cable (with GL-approval)		(025) 25 mm (050) 50 mm (100) 100 mm (150) 150 mm (200) 200 mm (250) 250 mm (000) Special length	

Accessories

1. Conduits for temperature sensors

Order number example

Type	Series	Process connection	Material	Sensor length
TFS	69-61	01	2	250

Your order number

TFS	69-61			
-----	-------	--	--	--

Process connection	Material	Sensor length L0 in mm
(01) G 1/2 male - G 1/4 female	(1) Stainless steel W.-Nr. 1.4571	(from sealing edge)
(02) G 3/4 male - G 1/4 female	(2) Brass SoMS 59	(017) 17 mm (standard)
(03) G 1 male - G 1/4 female	(3) Steel ST 37	(025) 25 mm (050) 50 mm (100) 100 mm (150) 150 mm (200) 200 mm (250) 250 mm (000) Special length

2. Thermal conductive paste for temperature sensors

Order number	Description
0699-002	Thermal conductive paste 50g, tube

3. Certificates

Order number	Description
923-0936	Single calibration certificate R9 for temperature measuring device
998-9992	Factory certificate EN10204-2.2

4. Electrical plugs

Order number	Description
908-0381	Electrical plug M 12 x 1, 4-pin, with moulded cable 1,5 m
907-0357	Electrical plug M 12 x 1, 4-pin, with screw terminal, 90° elbow
907-0334	Electrical plug M 12 x 1, 4-pin, with screw terminal, straight
908-0361	Electrical plug M 12 x 1, 5-pin, with moulded cable 1,5 m
907-0185	Electrical plug M 12 x 1, 5-pin, with screw terminal, 90° elbow
907-0177	Electrical plug M 12 x 1, 5-pin, with screw terminal, straight

5. Power supplies

Order number	Description
931-0001	Power supply for unit group UDS / UDPS / UTS (Supply 220 VAC)

The fastest way to more information:
 . . . just complete the order form below
 and fax it!



Fax to : **Barksdale Control Products GmbH**
 Dorn-Assenheimer Strasse 27
 D-61203 Reichelsheim / Germany
Fax-Nr.: +49 (0) 60 35 - 9 49-113

From : Name :
 Company :
 Department :
 Street / P.O.Box :
 Post Code / City :
 Telephone :
 Fax :
 e-mail :

Date :

Please send me detailed information about

- Mechanical Pressure Switches
- Electronic Pressure Sensors
- Electronic Pressure Switches
- Level Switches
- Continuous Tank Level Indicating Systems
- Level Probes
- Bypass Level Indicating Systems
- Flow Switches
- Mechanical Temperature Switches
- Electronic Temperature Sensors
- Electronic Temperature Switches
- Shear Seal- / Air Suspension Valves

In addition to the Electronic Temperature Transducers and Electronic Temperature Switches listed in this catalog our product range includes various other instrumentation and control equipment to monitor, measure and control

 **Pressure**

 **Temperature**

 **Level**

 **Flow**

We have the right solution for your measuring tasks.

Just contact us.

Our Products



03 / 02 KTE-EN 01/1

Barksdale Electronic Temperature Transducers / Switches

Specifications are subject to change without notice.

Barksdale

Represented by:

Control Products GmbH

Barksdale
Control Products GmbH
 Dorn-Assenheimer Strasse 27
 D-61203 Reichelsheim

Tel.: +49 - 60 35 - 9 49-0
 Fax: +49 - 60 35 - 9 49-111 und 9 49-113
 e-mail: Info@Barksdale.de

Web-Site: <http://www.barksdale.de>

Art.-Nr. 923-0877

